



Uninterruptible Power Supply
EVO DSP TT
10-100kVA

User's manual

Important Notice

Thank you for purchasing TECNOWARE UPS.

This document provides instructions about safety, installation and handling of the UPS. It is necessary to read the manual completely before working on this equipment.



Read the manual completely before working on this equipment!



Keep this manual near UPS for easy consultation!

Symbols



This symbol points out the instructions which are especially important.



This symbol points out the risk of electric shock if the following instruction is not obeyed.



This symbol points out the instructions, which may result in injury to the operator or damage to the equipment if not obeyed.

© Copyright 2011 TECNOWARE s.r.l. All rights reserved.
All trademarks are property of their respective owners.

TECNOWARE s.r.l.
www.service.tecnoware.com

This manual has been printed and edited by TECNOWARE s.r.l.
March 2011 edition - version 2.0

Index

1	Safety	4
2	Installation	5
2.1	Transportation	5
2.2	Unpacking	5
2.3	Storage	5
2.4	Location and Connection of the UPS	5
2.4.1	Environmental Requisites	5
2.4.2	Electrical Requisites	6
2.5	Connections.....	7
2.5.1	Internal Battery Connection	8
2.5.2	Power Connections.....	9
2.5.2.1	Protective Earth (Ground) Connections	9
2.5.2.2	Input Connection	9
2.5.2.3	Separated Bypass Mains Input Connection (Optional)	10
2.5.2.4	External Battery Connection.....	10
2.5.2.5	Output Connection	10
2.5.3	Communication Interfaces Connections.....	10
3	Operating Modes	11
3.1	Bypass Mode	12
3.2	Normal Mode	13
3.3	Battery Mode	13
4	Control and Monitoring	14
4.1	Front Panel	14
4.1.1	Keypad.....	14
4.1.2	Mimic Panel	15
4.1.3	Liquid Crystal Display (LCD) and User Menu	16
4.1.4	Buzzer.....	19
5	Operating Procedures	20
5.1	Commissioning	20
5.2	Decommissioning.....	20
5.3	Switching into Manual Bypass during Operation.....	21
5.4	Returning from Manual Bypass to UPS	21
5.5	Connection to a Generator.....	21
6	Operating Procedures for Parallel System	22
6.1	Introduction	22
6.2	Procedure for Commissioning and Start Up (First Installation)	22
6.3	Procedure for Transferring to Static Bypass	25
6.4	Procedure for Transferring to (Maintenance) Manual Bypass	25
6.5	Procedure for Switching OFF	25
7	Features and Operating Limits	26
7.1	Mains Limits for Normal mode.....	26
7.2	Bypass Mains Limits for Bypass mode	26
7.3	Battery Test	26
7.4	Overload Behavior	27
7.5	Electronic Short Circuit Protection	27

- 8 Communication Interfaces 28**
 - 8.1 RS232 Communication 28
 - 8.2 RS422 Communication 28
 - 8.3 Digital Inputs (UPS OFF and GEN ON) 29
 - 8.4 Free Contact Communication..... 29
- 9 Maintenance..... 30**
 - 9.1 Battery Fuses 30
 - 9.2 Battery..... 30
 - 9.3 Fans 30
 - 9.4 Capacitors..... 30
- 10 Troubleshooting 31**
- 11 Technical Specifications..... 34**
- 12 Internal Battery Location - Connection Instructions 36**
- 13 Internal Battery Location - Connection Diagram..... 38**

1 Safety



Information related to the safety of the UPS, loads and the user is summarized below. But the equipment should not be installed before reading this manual completely.



- ▶ The equipment may only be installed and commissioned by authorized technical persons.
- ▶ When the UPS is brought from a cold place to a warmer place, humidity in the air may cause condensation in the UPS. In this case, allow UPS to stand for two hours in the warmer place before beginning with the installation.
- ▶ Even if no connection has been done, hazardous voltages may exist on connection terminals and inside the UPS. Do not touch these parts.
- ▶ Connect the PE (Earth) ground connector before connecting any other cable.
- ▶ Do not put the Battery fuses into the fuse holder before operating the equipment and seeing the “NORMAL” message on the LCD.
- ▶ The connections shall be made with cables of appropriate cross-section in order to prevent the risk of fire. All cables shall be of insulated flexible type (tri-rated) and shall not be laid out on the walk path of persons. Cables crossing a path must be protected in accordance with local electrical and safety regulations.
- ▶ Do not expose UPS to rain or liquids in general. Do not put any solid objects into any access/vent hole or space.
- ▶ The equipment shall be operated in an environment, which is specified in “Location and Connection of the UPS” section of this manual.
- ▶ Affix a label bearing the following expression, on the distribution panels feeding the UPS:
“Isolate the Uninterruptible Power Supply (UPS) before working on this circuit”.
- ▶ Do not plug the communication cables in or out during lightening or electrical storms.
- ▶ The equipment shall only be maintained and fixed by authorized technical persons.
- ▶ In case of a fault situation (damaged cabinet or connections, penetration of foreign materials into the cabinet etc.) de-energize the UPS immediately and consult with Tecnoware Technical Service.
- ▶ Used/dead batteries must be disposed of at an authorized waste disposal centre - local regulations may apply - batteries must not be put in a land fill.
- ▶ Keep this manual nearby the UPS for easy consultation.
- ▶ The equipment shall be packed properly during transportation.
- ▶ The equipment is compliant with the European Community directives. Hence it is marked:



2 Installation

2.1 Transportation

The UPS must remain in a vertical position throughout the transportation. Make sure that the floor can support the weight of the system - check with building engineer if not sure.

2.2 Unpacking



Equipment and batteries whose packaging is damaged during transportation shall be inspected by a qualified technical person before starting with the installation.

The procedure is as follows:

- ▶ Remove the bands and the protective packaging from the UPS.
- ▶ Use suitable equipment to remove the UPS from the pallet.



The equipment shall be packed properly during transportation. Therefore it is recommended to keep the original package for future needs (e.g. further transportation or return to Service Department).

Check if the following are provided with the equipment:

- ▶ Key of the cabinet door
- ▶ Battery fuses (three pieces)
- ▶ Test report

2.3 Storage

Recommended storage temperature, humidity and altitude values are listed in the “Technical Specifications” section.

If the batteries will be stored for longer than 2 months, they must be charged periodically. Charge period depends on the storage temperature. The relationship is as shown below:

- ▶ Every 9 months if the temperature is below 20°C.
- ▶ Every 6 months if the temperature is between 20°C and 30°C.
- ▶ Every 3 months if the temperature is between 30°C and 40°C.
- ▶ Every 2 months if the temperature is over 40°C.

2.4 Location and Connection of the UPS

2.4.1 Environmental Requisites

This product meets the safety requirements for devices to be operated in restricted access locations according to EN 60950-1 safety standard, which states that the owner should guarantee the following:

- ▶ Access to the equipment can only be gained by service persons or by users who have been instructed about the reasons for the restrictions applied to the location and about any precautions that shall be taken.

- ▶ Access is through the use of a tool or lock and key, or other means of security and is controlled by the authorized person responsible for the location.

Recommended operating temperature, humidity and altitude values are listed on the “Technical Specifications” section. Air conditioning may be required to provide these values.

Other requisites are:

- ▶ The equipment and the batteries shall not be exposed to direct sunlight or placed near to a heat source.
- ▶ Do not expose UPS to rain or any liquids in general. Do not introduce any solid objects.
- ▶ Avoid dusty environments or areas where dust of conductive or corrosive materials is present.
- ▶ Air outlets of the UPS are on sides, front and back. Leave at least 75 cm at the front and both sides and 50 cm at the back for maintenance and ventilation.

2.4.2 Electrical Requisites

The installation must comply with local national installation regulations.

The electrical distribution panels for the mains and separate Bypass mains inputs must have a protection and disconnection system. Disconnection devices used in these panels shall disconnect all line conductors and the neutral conductor simultaneously. The following table shows the recommended size of the mains and separate Bypass mains input protection devices (thermal, magnetic and differential) and the cable cross-sections for the linear loads.

UPS Rating	Input thermal protection	Bypass mains input thermal protection	Input cable cross-section	Bypass mains input cable cross-section	Battery cable cross-section	Neutral Cable Cross section	Leakage current protection*
10 kVA	25 A	25 A	6 mm ²	6 mm ²	6 mm ²	10 mm ²	30 mA
15 kVA	25 A	25 A	6 mm ²	6 mm ²	6 mm ²	10 mm ²	30 mA
20 kVA	40 A	40 A	10 mm ²	10 mm ²	10 mm ²	16 mm ²	30 mA
30 kVA	63 A	63 A	16 mm ²	16 mm ²	16 mm ²	25 mm ²	30 mA
40 kVA	80 A	80 A	16 mm ²	16 mm ²	16 mm ²	25 mm ²	30 mA
60 kVA	100 A	100 A	25 mm ²	25 mm ²	25 mm ²	35 mm ²	30 mA
80 kVA	125 A	125 A	35 mm ²	35 mm ²	35 mm ²	50 mm ²	30 mA
100 kVA	160 A	160 A	35 mm ²	35 mm ²	35 mm ²	50 mm ²	30 mA

Input magnetic protection devices shall have D characteristic.

*Load leakage currents are added to those generated by the UPS. If loads with high leakage currents are present, adjust this value accordingly. It is recommended to adjust the protective device after measuring the total leakage current with the UPS installed and operational with the intended load.

During transitory phases (power failure, return and voltage fluctuations) short leakage current peaks may occur. Make sure that the protection is not activated in such cases.



If the loads have a nonlinear characteristic, the current on the mains input, separate Bypass mains input may have a value that is 1.5-2 times the current phase value during operation. In this case, size the neutral cables and the input/output protection accordingly.



According to EN 62040-1-2, the user shall place a warning label on the input distribution panel and the other primary power isolators, in order to prevent the risk of electric shock caused by a fault voltage on the UPS. The label shall carry the following wording:



ISOLATE THE UNINTERRUPTIBLE POWER SUPPLY (UPS) BEFORE WORKING ON THIS CIRCUIT

2.5 Connections



Connections shall be done by authorized technical staff only.



When the UPS is brought from a cold place to a warmer place, humidity of the air may condensate in it. In this case, wait for two hours before beginning with the installation.

UPS front side

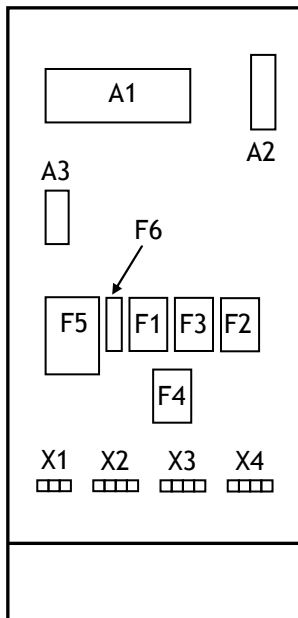

The layout of the Communication Interface board, Parallel board, slot for SNMP Interface, circuit breakers and connection terminals, is shown below (for accessing open the UPS front door):

A1: Communication Interface board

A2: Parallel board (optional)

A3: Slot for SNMP Interface: SNMP (Simple Network Management Protocol) Interface is optional.

ATTENTION: bring the 2 dip switches of A1 board to ON position before using SNMP Interface.

F1: Input mains circuit breaker

F2: Output circuit breaker

F3: Manual Bypass circuit breaker

F4: Static Bypass circuit breaker (optional)

F5: Battery circuit breaker

F6: Inrush circuit breaker

X1: Battery terminals (for connecting the batteries)

X2: Input terminals (for connecting AC Input mains)

X3: Bypass terminals (optional - for connecting AC Input mains for Split Bypass)

X4: Output terminals (for connecting Output line)

2.5.1 Internal Battery Connection

The models EVO DSP TT 10-30 KVA can be equipped with internal batteries. In such case these devices may have very hazardous voltages on the Battery terminals.

When the UPS has battery inside, before doing any operation please do the following points:



1. Remove the back UPS cover to access to the battery pack.
2. Connect the positive battery terminal A (see the following figure).
3. Connect the positive battery terminal B (see the following figure).
4. Connect the positive battery terminal C (see the following figure).
5. Replace the back UPS cover.

PAY ATTENTION: RISK OF ELECTRICAL SHOCK - HIGH BATTERY VOLTAGE



A, B and C battery terminals are disconnected in factory to reduce the risk of electrical shock during shipment. After points 2, 3 and 4 the **NOMINAL TOTAL BATTERY VOLTAGE** is about 744 VDC (there are 62 batteries 12 VDC serial connected).

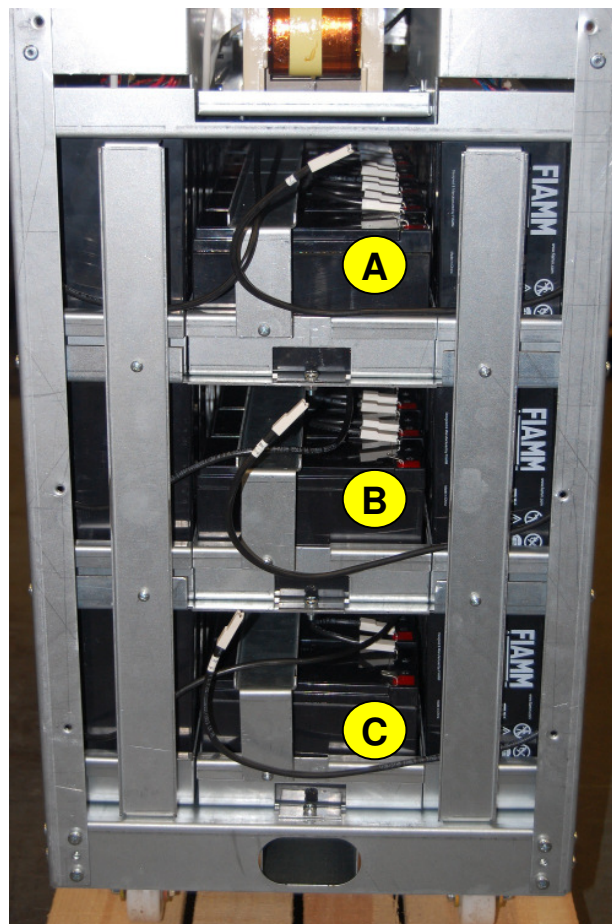
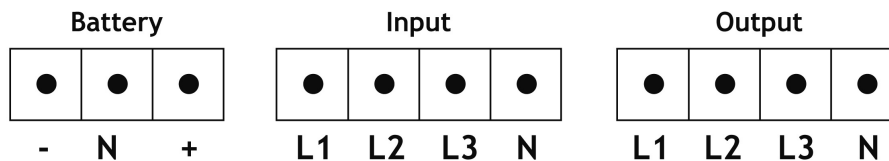

Figure - A, B and C Battery terminals connections

2.5.2 Power Connections

The power screw terminals are located on the lower front side of the UPS. Refer to the names of each terminal to identify it during connection.



Connection terminals for all standard models

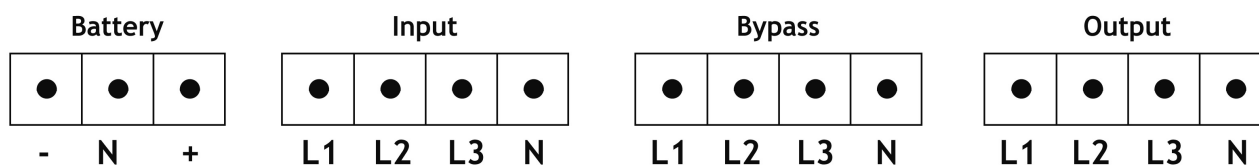

Connection terminals for all models with optional split Bypass



Battery terminals: use only to connect external battery.

Cables shall be passed through the hole under the connection terminals.

Make sure that all circuit breakers are “OFF”/“0” before starting with the installation.

Connections shall be done in the order below only.

2.5.2.1 Protective Earth (Ground) Connections



The device shall be earthed for a safe and reliable operation. Connect the PE ground connectors before connecting any other cable

Input Protective Earth connection terminal (PE) of the UPS shall be connected to ground with a low impedance connection.

PE terminals of the loads shall be connected to Output Protective Earth terminal of the UPS.

If there is an external battery cabinet present, it shall be grounded via Battery Protective Earth terminal of the UPS. Battery case must be earthed only. Do not connect any DC/battery point to PE earth.

2.5.2.2 Input Connection



Bring the circuit breaker on the distribution panel to “OFF”/“0” position before making the connections.

Connect the phases to input (X2) L1, L2 and L3 terminals. Connect neutral to N terminal of X2

A definite phase sequence is needed for the UPS to operate. If you encounter “INP SEQ FAIL” alarm message at start-up, stop and switch off the UPS, ensure the protection devices (breakers/isolators) on the input distribution panels are “OFF”/“0”, then interchange any two phases on the UPS input only.

2.5.2.3 Separated Bypass Mains Input Connection (Optional)



Bring the circuit breaker on the distribution panel to “OFF” or “0” position before making the connections

Connect the phases to Bypass (X3) L1, L2 and L3 terminals.

Make sure that the phases have the same sequence with the input supply.

Connect neutral to N terminal of X3.

2.5.2.4 External Battery Connection



Do not put the Battery fuses into the fuse holder (F5) before operating the equipment and seeing the “NORMAL” message on the LCD.



Devices with internal batteries may have dangerous voltages on the Battery terminals

To connect external batteries, do the following:

- ▶ Switch the circuit breaker of the external batteries to “OFF”/“0” position.
- ▶ Connect the (-) pole of the external batteries to the Battery (-) terminal,
- ▶ Connect the (+) pole of the external batteries to the Battery (+) terminal,
- ▶ Connect the midpoint of the external batteries to the Battery (N) terminal.



Danger of explosion and fire if batteries of the wrong type are used.

2.5.2.5 Output Connection



To enable the short circuit protection feature of the UPS, each load shall be fed over a separate circuit breaker chosen according to the load current. This may provide quick disconnection of the short circuited load and operation continuity of the other loads. To obtain maximum protection, the rating of each individual load circuit breaker shall have the minimum value, which is enough to carry the full load current continuously.



Rated apparent and active power of the loads shall be less than the UPS power ratings.

Connect the loads to Output (X4) L1, L2, L3 and N terminals.

2.5.3 Communication Interfaces Connections

Related information is given in “Communication Interfaces” section.

3 Operating Modes

There are three operating modes, which differ in the path of the energy flow.

UPS block diagrams and the energy flow path in each operating mode is shown below:

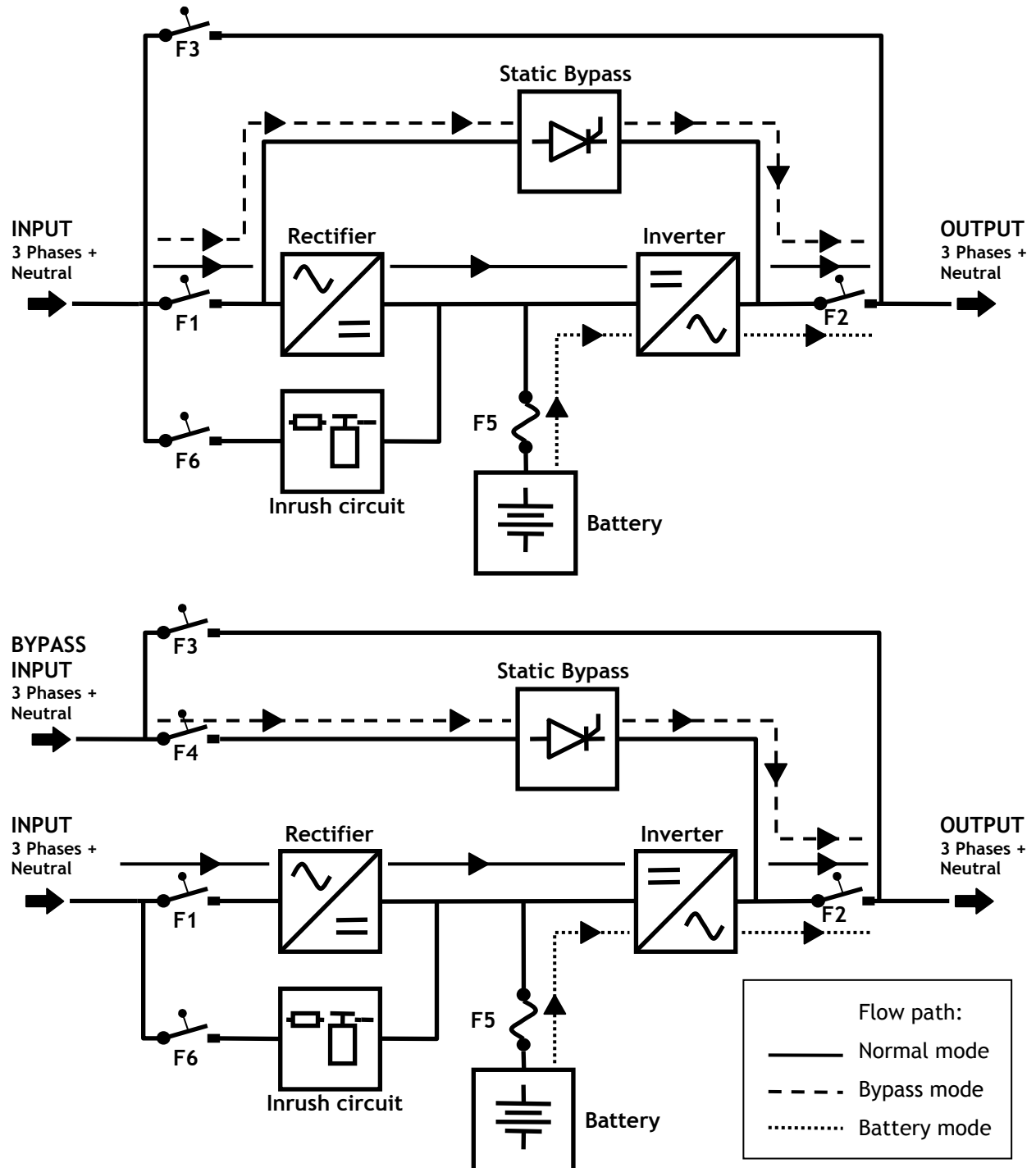

Figure - Block diagram and energy flow paths
(up: without Separate Bypass mains Input - down: with Separate Bypass mains Input)

When UPS has no separate Bypass mains input, Bypass line is also fed from the mains input. Thus, if such a device is in question, mains input shall be comprehended when the Bypass mains input is referred in the following sections of the manual.

UPS behavior at the start-up is different from the usual operation. The UPS can only operate in Bypass mode during start-up. So, in order for the UPS to start-up, frequency/waveform/RMS value of the Bypass mains voltage shall be in acceptable limits and Bypass shall be enabled.

After start-up, the following applies:

Operating mode depends on the priority, Inverter, Rectifier and Bypass preferences made by the user and mains, separate Bypass mains and battery voltages.

Priority and Inverter, Rectifier and Bypass preferences can be set by using the “COMMANDS” menu and “EXTENDED CMNDS” submenu.

If operation in any of these modes is impossible, output voltage will not be present. In this case, loads will not be fed, and “VSECFLR” alarm message is shown on the LCD instead of operating mode.

3.1 Bypass Mode

Devices without separate Bypass mains input, energy is drawn from the mains. In devices with separate Bypass mains input, energy is drawn from the separate Bypass mains.

Loads are fed via static Bypass line.

Output voltage has the same amplitude, frequency and waveform as the input voltage.

Current drawn by the loads are only limited by the thermal/magnetic breakers over the energy flow path.

Voltage, frequency and waveform of the Bypass supply shall be within their tolerance limits, and Bypass shall be enabled for the UPS to operate in this mode.

When the upper provisions are met, the UPS works in Bypass mode in the following conditions:

- ▶ During the start-up;
- ▶ If the Bypass priority is selected;
- ▶ If the Inverter is disabled or blocked;
- ▶ In case of a prolonged Overload.

ECO Mode

- ▶ You can save energy by selecting the Bypass priority. Efficiency in Bypass mode is higher than the efficiency in Normal mode. If the Bypass priority is selected, the UPS will operate in Bypass mode whenever the frequency/waveform/RMS value of Bypass mains voltage is within their tolerance limits. If the Bypass voltage goes beyond these limits, the UPS switches into normal operation.



Bypass mode does not provide perfect stability in frequency/waveform/RMS value of the output voltage like in Normal mode. Thus, the use of this mode should be carefully executed according to the level of protection required by the application.



Bypass mode does not provide electronic short circuit protection like in Normal mode. If a short circuit occurs on the output during Bypass operation, the thermal/magnetic protection will act and all loads will be de energized - load will be stopped.



Prolonged overloads may cause the thermal/magnetic protection to act. In this case, all loads will be de energized - load output will be stopped.

3.2 Normal Mode

Energy is drawn from the mains input.

Loads are fed via the Rectifier and the Inverter. The AC voltage at the input is converted to a DC voltage by the Rectifier. The Inverter converts this DC voltage to an AC voltage with a stable sinusoidal waveform, amplitude and frequency.

Output voltage is sinusoidal and has a regulated amplitude and frequency. It is independent from the input voltage.

The Inverter is synchronized in frequency with the Bypass mains input to enable load transfer to the Bypass supply without any interruption, in case of an Overload or Inverter failure.

Voltage and frequency of the mains input shall be within their tolerance limits, and both the Rectifier and the Inverter shall be enabled for the UPS to operate in this mode.

When the upper provisions are met, the UPS works in Normal mode in the following conditions:

- ▶ If the Inverter priority is selected.
- ▶ If the Bypass priority is selected but Bypass is disabled or frequency/waveform/RMS value of Bypass mains voltage is not within acceptable limits.

3.3 Battery Mode

Energy is drawn from the batteries. Loads are fed via the Inverter.

Output voltage is sinusoidal and has a regulated amplitude and frequency. It is independent from the battery voltage.

Battery voltage shall be within acceptable limits and the Inverter shall be enabled for the UPS to operate in this mode.

When the upper provisions are met, the UPS works in Battery mode in the following conditions:

- ▶ If Rectifier is disabled.
- ▶ If the Rectifier is disabled or frequency/waveform/RMS value of mains voltage is not in acceptable limits.

4 Control and Monitoring

4.1 Front Panel

The front panel located on the upper part of the UPS informs the user about operating status, alarm conditions and measurements. It also provides access to controls and configuration parameters.





Front panel shown below consists of three parts:

1. Mimic panel provides basic information about the energy flow path and existing alarms;
2. LCD (liquid crystal display) offers detailed information and provides access to controls;
3. Keypad enables the user to move in the menu and to make selections.



4.1.1 Keypad

Functions of the buttons are given below:

BUTTON	SYMBOL	DEFINITION
MENU	 MENU	To access to a menu or to exit from the current menu.
UP	 UP	Scrolls the available menus/values upwards. It increases the value each time it is pushed when changing a parameter.
DOWN	 DOWN	Scrolls the available menus/values downwards. It decreases the value each time it is pushed when changing a parameter.
ENTER	 ENTER	Enters the menu displayed on the screen. It makes selections or confirms the choice/changes made.

4.1.2 Mimic Panel

Mimic panel is a diagram, which shows the path of energy flow in the UPS by means of several LED's. Definitions of LED status are shown below:

LED's			
ID	COLOR	DEFINITION	STATE
Line 1	Green	Input mains voltage is OK and Rectifier is active.	Steady
		Input mains voltage is OK and Rectifier is inactive.	Flashing
		Input mains voltage is very close to its upper/lower limit and Rectifier is active.	
		Input mains voltage is not OK.	Off
Line 2	Green	Bypass voltage is OK.	Steady
		Bypass voltage is not OK and output voltage is synchronized to the Bypass voltage.	Flashing
		Bypass mains voltage is not OK and output voltage is not synchronized to the Bypass voltage.	Off
Battery	Red	Battery mode is active and battery voltage is OK.	Steady
		UPS is performing Battery Test and battery voltage is OK.	
		Battery mode is active and battery voltage is close to its lower limit (energy available in the battery is about to be depleted).	Flashing
		Battery Test is active and battery voltage is close to its lower limit (energy available in the battery is about to be depleted).	
		Rectifier is active and able to supply whole power required by the Inverter.	Off
Inverter	Green	Load is fed via Inverter.	Steady
		Inverter is not active.	Off
Load	Green	Load is powered.	Steady
		Load is powered but UPS is overloaded.	Flashing
		Output voltage is not OK.	Off
Bypass	Yellow	Load is fed via static Bypass line.	Steady
		Bypass is not active.	Off
Fault	Red	No alarms.	Off
		A minor priority alarm is present.	Flashing
		A major priority alarm is present.	Steady

4.1.3 Liquid Crystal Display (LCD) and User Menu

LCD provides detailed information about device status, alarms and measurements. It also enables the operator to manage the UPS. All information, commands and configuration parameters are given in a menu, which has the following structure:

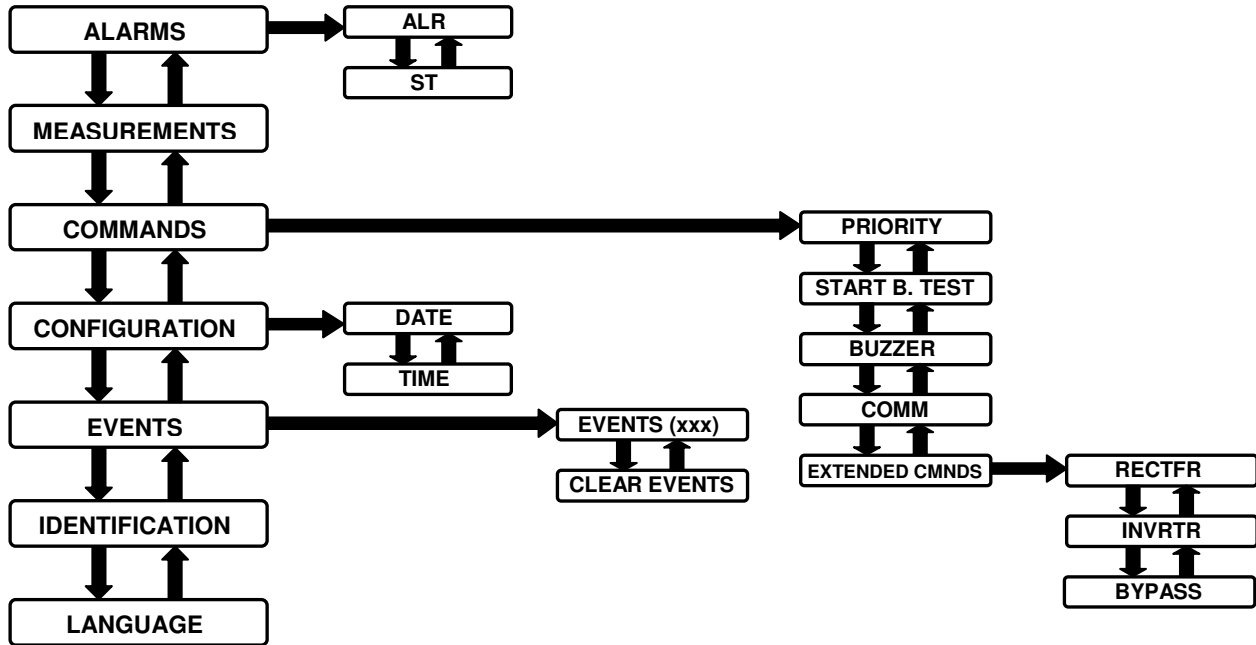

LCD consists of two rows and has the following structure:

Upper row: operating mode notification or “VSECFLR” alarm message
Lower row: menu, submenu, measurements

If there is no voltage on the output, “VSECFLR” alarm message is displayed on the upper row.

Operating mode is one of the notations below:

OPERATING MODE NOTATIONS	
NORMAL	Normal mode
BYPASS	Bypass mode
BATT.	Battery mode

Menu and submenu descriptions are given below.

“ALARMS” MENU	
ALR = “XXXXXXXXXXXX”	12 digit service codes.
ST = “XXXX-XXXXXXXX”	Note these numbers before referring to Technical Service.

Alarm codes and names can be seen by entering into “ALR” submenu.

“ALARMS” table, with code, name and definition for each alarm, is given below.

All alarms except “VSEC NOT OK” are minor priority alarms.

ALARMS" TABLE		
CODE	NAME	DEFINITION
A01	BYP BADSHAPE	Bypass mains voltage is different than the Inverter reference signal (e.g. its frequency is beyond synchronization limits or it has a Total Harmonic Distortion > %10).
A02	BYP VOL HIGH	Bypass mains voltage is higher than its upper limit.
A03	BYP VOL LOW	Bypass mains voltage is lower higher than its lower limit.
A06	BYP SYN FAIL	Frequency of Bypass mains voltage is beyond the frequency range for Bypass operation or Bypass mains voltage is very low.
A07	BYP SEQ FAIL	Phase sequence of Bypass mains voltages is not OK.
A08	MNBYP SW ON	Manual Bypass breaker is "ON"/"1".
A09	INV TMP HIGH	Inverter block temperature is very high.
A10	OUT OVERLOAD	RMS current drawn from any of the output lines exceeds its nominal value.
A11	BYP ACT	Bypass mode is activated.
A12	INV NOT ACT	Inverter is not started due to a fault.
A13	INV BLCK	Inverter operation is automatically stopped due to a fault.
A14	VSEC NOT OK	Output voltage is beyond its limits.
A17	INP VOL HIGH	Input line/neutral voltage is higher than its upper limit.
A18	INP VOL LOW	Input line/neutral voltage is lower than its lower limit.
A21	INP SYN FAIL	Frequency of mains voltage is beyond the frequency range for Normal operation or mains voltage is very low.
A22	INP SEQ FAIL	Phase sequence of input mains voltages is not OK.
A23	REC TMP HIGH	Rectifier block temperature is very high.
A24	REC OVERLOAD	RMS current drawn from any of the input lines exceeds its nominal value.
A25	VDC HIGH	DC bus voltages is higher than its upper limit
A26	VDC LOW	DC bus voltages is lower than its lower limit. may mean that the battery is empty during Battery mode.
A27	REC NOT ACT	Rectifier is not started due to a fault.
A28	REC BLCK	Rectifier operation is automatically stopped due to a fault.
A30	TESTING BATT	The Battery Test is being performed.
A31	REDUND. LOST	Redundancy lost condition in Parallel System
A33	REC OFF	Rectifier is inactive.
A34	INV OFF	Inverter is inactive.
A35	BYP OFF	Bypass mode is inactive.
A36	BYP PRI HIGH	Priority is Bypass.
A37	BATT DISCHAR	Batteries are discharging after a mains failure.
A38	VDC NOT OK	DC bus voltage is out of its normal range.
A39	T-AMP HIGH	Ambient temperature exceeds its upper limit.
A40	GENSET ON	"Generator Friendly" operation is activated.
A41	EMG STOP ON	Emergency stop is activated.
A42	MINOR ALR	Minor priority alarm.
A43	MAJOR ALR	Major priority alarm.
A44	BATT TS FAIL	Batteries failed in the Battery Test.
A45	BATT CR OPEN	Battery circuit breaker is open.
A47	INV RX T-OUT	Communication between the Inverter and the front panel is lost.
A48	REC RX T-OUT	Communication between the Rectifier and the front panel is lost.

"MEASUREMENTS" MENU		
MEASUREMENT		DEFINITION
LD	= XXX,XXX,XXX %	Ratio of the actual Inverter active power of each line to its nominal value.
Vsc	= XXX,XXX,XXX V	Output line/neutral voltages.
Isc	= XXX,XXX,XXX A	Output line currents.
Fo	= XX.X Hz	Frequency of output Line/Neutral voltages.
Vby	= XXX,XXX,XXX V	Bypass Line/Neutral voltages.
Vin	= XXX,XXX,XXX V	Input Line/Neutral voltages.
Iin	= XXX,XXX,XXX A	Input line Currents.
Fin	= XX.X Hz	Frequency of input Line/Neutral voltages.
Vdc	= XXX,XXX V	Positive and negative DC bus voltages.
Vbat	= XXX,XXX V	Positive and negative battery branch voltages.
Ibat	= ±XXX,±XXX A	Positive and negative battery branch currents. Positive during charge, negative during discharge.
Tbat	= XXX °C	Ambient temperature.

"COMMANDS" MENU		
PRIORITY	= INVRTR/BYPASS	Selects the priority for Normal mode or Bypass mode. Push ENTER to switch between INVRTR and BYPASS.
START B. TEST		Push ENTER to start the Battery Test.
BUZZER	= ENBLD/DSBLD	Enable or disable the buzzer. Push ENTER to switch between ENBLD and DSBLD.
COMM	= RS232/RS485	Push ENTER to switch between RS232/RS485 communication.
EXTENDED CMNDS		Push ENTER to enter this submenu.

"EXTENDED CMNDS" SUBMENU		
RECTFR	= ENBLD/DSBLD	Enable or disable operation of the Rectifier block. Push ENTER to switch between ENBLD and DSBLD.
	= BLCKD	Can be seen only when the Rectifier is blocked. Push ENTER to remove the blockage and enable the Rectifier.
INVRTR	= ENBLD/DSBLD	Enable or disable the operation of the Inverter block. Push ENTER to switch between ENBLD and DSBLD.
	= BLCKD	Can be seen only when the Inverter is blocked. Push ENTER to remove the blockage and enable the Inverter.
BYPASS	= ENBLD/DSBLD	Enable or disable the operation of the Bypass thyristors. Push ENTER to switch between ENBLD and DSBLD.

"CONFIGURATION" MENU	
DATE = "dd-mm-yyyy"	Shows system date in dd-mm-yyyy format (dd = day, mm = month, yyyy = year). Use ENTER, UP and DOWN keys to change the date.
TIME = "hh:mm:ss"	Shows system time in hh-mm-ss format (hh = hour, mm = minutes, ss = seconds) Use ENTER, UP and DOWN keys to change the time.

"EVENTS" MENU	
EVENTS (xxx)	Shows last 380 events (alarms) of system. The total number of stored events is xxx. To look stored events, you must press ENTER key and then use UP/DOWN keys.
CLEAR EVENTS	Clears all events stored in EPROM after verification of clear process.

"EVENTS (xxx)" SUBMENU	
YYY : AAAAAAAAAAAAA	"YYY" shows progressive number of event and "AAAAAAAAAAAA" shows the event name (for event names see "ALARMS" table on page 17). The 001 event is the last stored event. To look event details, you must press ENTER key and then use UP/DOWN keys.
DATE = dd/mm/yyyy	Displays date of event occurring.
TIME = hh:mm:ss	Displays time of event occurring.
A:XXXX-XXXX-XXXX	Displays alarm status when event occurs.
ST=XXXX-XXXXXXXX	Displays status string when event occurs.

"IDENTIFICATION" MENU	
"X/X XXX kVA"	Shows number of Input/Output Phases and Output Nominal Apparent Power.
FW = "XX"	Shows Firmware version

4.1.4 Buzzer

Buzzer warns the user about the present alarms. It can be disabled by using the "COMMANDS" menu.

BUZZER	
STATE	DEFINITION
Off	No alarms
Discontinuous	A minor priority alarm is present
Steady	A major priority is present

5 Operating Procedures

This chapter defines the operating procedures to be followed to activate, deactivate and manage the UPS. The instructions shall be applied in the sequence in which they are written only - do not alter or miss a step - to do so may cause a fault or failure.

5.1 Commissioning

- 1 Make the connections according to the “Installation” section.
- 2 Switch the circuit breaker on the Input distribution panel to “ON”/“1” position.
- 3 Switch the circuit breaker on the separate Bypass distribution panel to “ON”/“1” position.
- 4 If the Bypass mains input is separate, bring the Bypass circuit breaker (F4) to “ON”/“1” position.
- 5 Bring the Input circuit breaker (F1) to “ON”/“1” position.
- 6 Wait to see the “BYPASS” message on the LCD display.
- 7 Bring the Inrush circuit breaker (F6) to “ON”/“1” position.
- 8 Bring the Output circuit breaker (F2) to “ON”/“1” position.
- 9 Wait to see the “NORMAL” message on the LCD display; then set date and time.
- 10 Only if there are external battery cabinets: bring the circuit breaker of the external battery cabinets to “ON”/“1” position.
- 11 Bring the Battery circuit breaker (F5) to “ON”/“1” position.



The UPS starts up in Bypass mode and automatically switches to Normal mode. “NORMAL” message will not be displayed until the UPS switches to Normal mode. Frequency/waveform/RMS value of the Bypass mains voltage shall be within acceptable limits and Bypass shall be enabled for the UPS to start-up. Voltage and frequency of the mains input shall be within their tolerance limits, and both the Rectifier and the Inverter shall be enabled for the UPS to operate in Normal mode.

5.2 Decommissioning

- 1 Bring the Output circuit breaker (F2) to “OFF”/“0” position.
- 2 Bring the Input circuit breaker (F1) to “OFF”/“0” position.
- 3 Bring the Inrush circuit breaker (F6) to “OFF”/“0” position.
- 4 Bring the Manual Bypass breaker (F3) to “OFF”/“0” position.
- 5 If the Bypass mains input is separated, bring the Bypass circuit breaker (F4) to “OFF”/“0” position.
- 6 Bring the Battery circuit breaker (F5) to “OFF”/“0” position.
- 7 Bring the circuit breaker of the external battery cabinets to “OFF”/“0” position.
- 8 Switch the circuit breaker on the Input distribution panel “OFF”/“0”.
- 9 Switch the circuit breaker on the separate Bypass distribution panel “OFF”/“0”.



In the event of an extended period of UPS inactivity, the batteries must be charged periodically in order to prolong battery life. The charge period, which depends on the temperature, is given in the “Storage” section of the manual.

5.3 Switching into Manual Bypass during Operation

Manual Bypass enables the user to isolate the electronic circuitry of the UPS from the mains and the load without interrupting the load operation by connecting the loads directly to the Bypass supply.

This feature is useful while performing maintenance or service and shall only be executed by authorized technical service personnel.



Maintenance and service may only be performed by authorized technical personnel

- 1 Bring the manual Bypass circuit breaker (F3) to “ON”/“1” position.
- 2 Make sure that the UPS switches into Bypass mode (see “BYPASS” message on the LCD).
- 3 Bring the Input circuit breaker (F1) to “OFF”/“0” position.
- 4 Bring the Inrush circuit breaker (F6) to “OFF”/“0” position.
- 5 If the Bypass mains input is separated, bring the Bypass circuit breaker (F4) to “OFF”/“0” position.
- 6 Bring the Output circuit breaker (F2) to “OFF”/“0” position.
- 7 Bring the Battery circuit breaker (F5) to “OFF”/“0” position.
- 8 LCD and buzzer will stop operation in a few minutes.



During manual Bypass operation, loads are fed directly from Bypass mains. Therefore no protection against mains disturbances or interruptions is present.



Although all breakers except F3 are “OFF”/“0” during manual Bypass operation, hazardous voltages are present on the terminals, EMC filters and measurement circuits.

5.4 Returning from Manual Bypass to UPS

- 1 Bring the Output circuit breaker (F2) to “ON”/“1” position.
- 2 Bring the Input circuit breaker (F1) to “ON”/“1” position.
- 3 Wait to see the “BYPASS” message on the LCD.
- 4 Bring the Inrush circuit breaker (F6) to “ON”/“1” position.
- 5 If the Bypass mains input is separated, bring the Bypass circuit breaker (F4) to “ON”/“1” position.
- 6 Bring the manual Bypass circuit breaker (F3) “OFF”/“0” position.
- 7 Wait to see the “NORMAL” message on the LCD.
- 8 Bring the Battery circuit breaker (F5) to “ON”/“1” position.

5.5 Connection to a Generator

If the input power is supplied by a generator, set the digital input “GEN ON” high. This ensures “Generator Friendly” operation by smoothing the increment of the current drawn from the generator, during transition from Battery mode to Normal mode.

When this is done, “GENSET ON” alarm will be shown. Connection details are given in the “Communication Interfaces” section.

6 Operating Procedures for Parallel System

6.1 Introduction

EVO DSP TT UPS are designed according to high MTBF figures with increased reliability but in case of necessity, a second (or more) EVO DSP TT UPSs can be connected in parallel redundant configuration for supplying the very critical load to increase reliability. Maximum of 4pcs of identical power and specification EVO DSP TT can be connected in parallel.

If power demand increases in a certain UPS application exceeding the power rating of an already installed stand-alone UPS, then a second (or more) UPS of the same model and power rating can be added in parallel to the existing UPS to increase the output power capacity.

The AC inputs of all UPSs in the Parallel System are connected to the same mains, and all the AC outputs are connected to each other. Each UPS has its own battery pack. The critical load is connected to the common output of the Parallel System. There are also some signal cable connections between the UPS units necessary for parallel operation, and will be described later.

6.2 Procedure for Commissioning and Start Up (First Installation)

- 1 First of all be sure each UPS of the Parallel System is equipped with Parallel board and is factory parallel configured.
- 2 Before switching on the UPSs, make sure that electrical connections have been made as shown in diagram below:

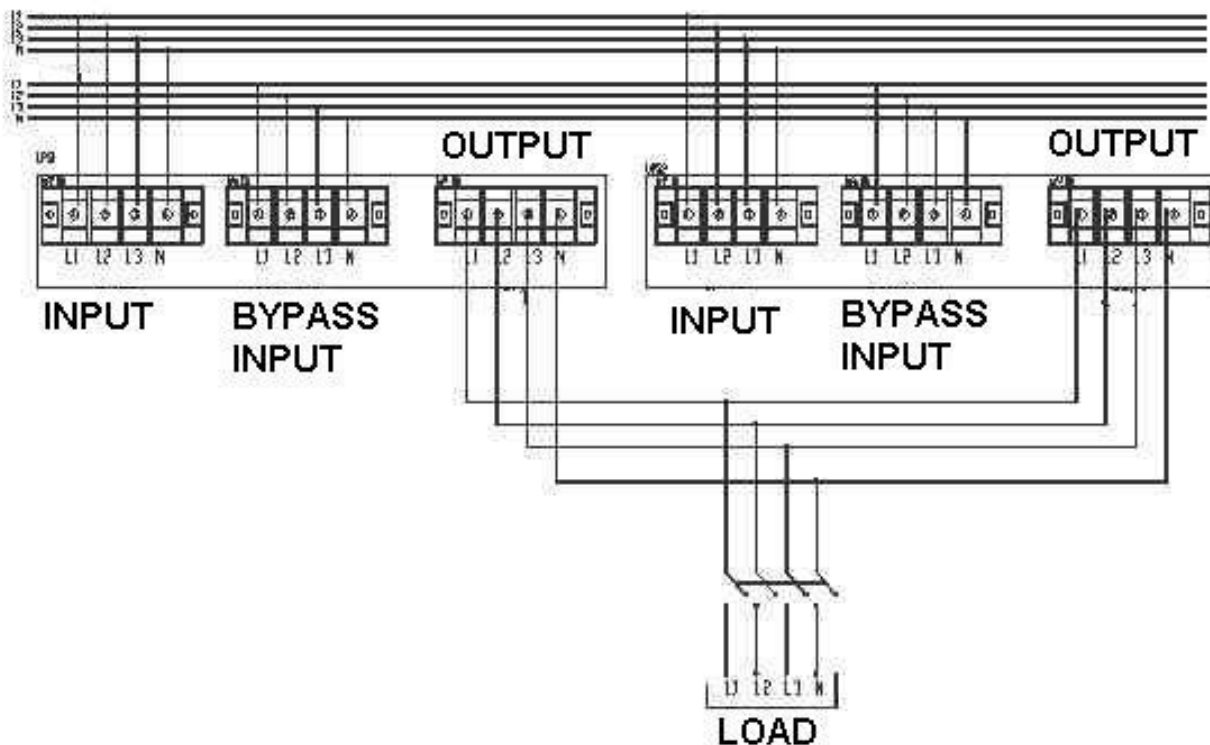

Figure - Connections of Parallel UPSs (with split Bypass option)

- 3 The communication of Parallel System is made through CAN-BUS protocol. Before starting up the UPSs, make the connection of communication cables between UPSs as per below diagram:

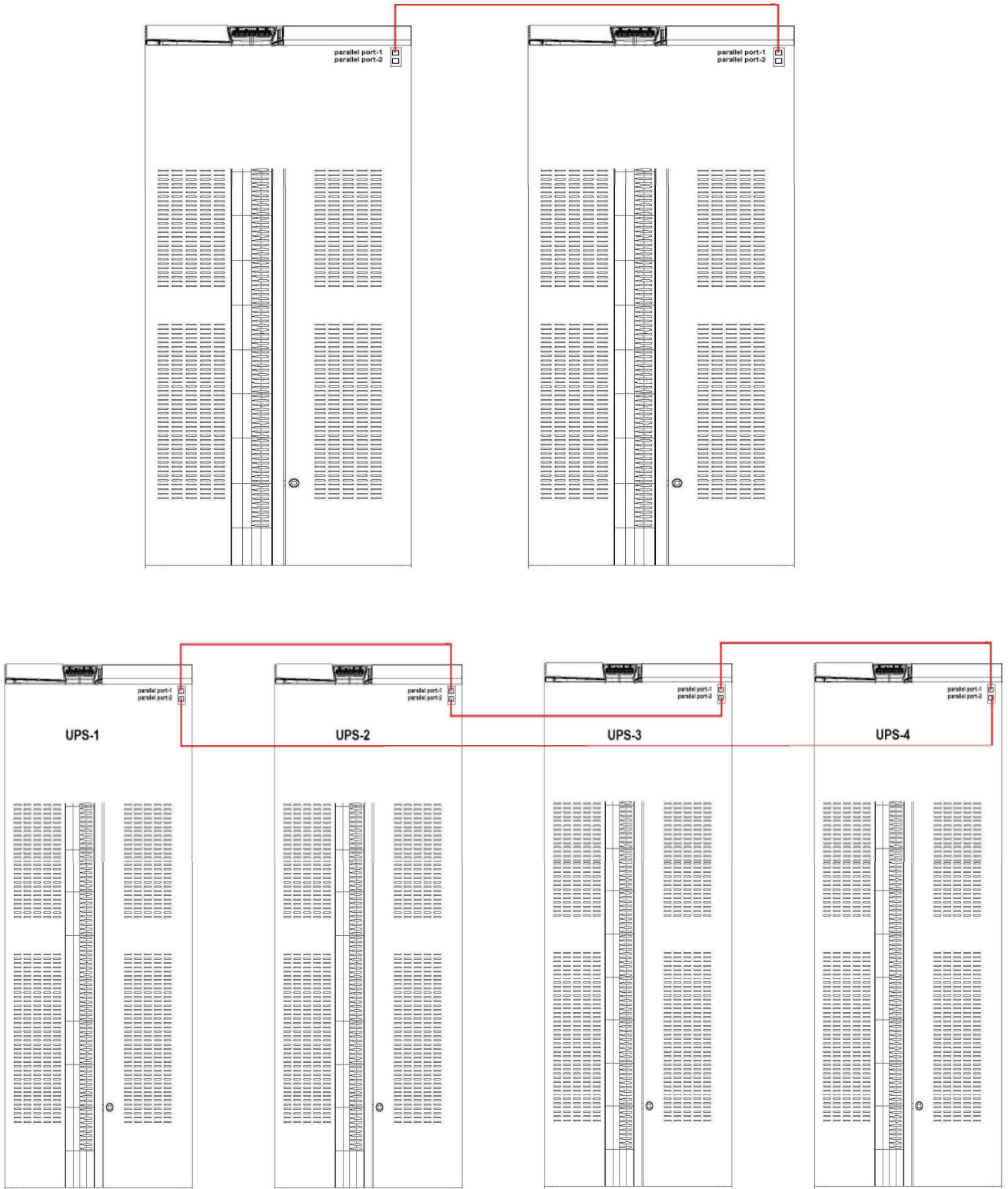

Figure - Communication cables connections between Parallel UPSs



Do not remove the communication cables between the UPSs during parallel operation.

In case this communication cable is removed or damaged during parallel operation and the communication is lost, then the slave UPS which can not communicate with the master UPS and it shall disconnect its output and maintain the OFF condition. The other UPSs shall continue their normal operation.

In such a case, this UPS should be turned off completely in order to insert its communication cable again and then switched on again. Do not try to insert the communication cable while it is operating.

- 4 All breakers (F1, F2, F3, F4 (optional), F5 and F6) should be in “OFF”/“0” position.
- 5 Switch “ON”/“1” the Input circuit breaker (F1) of the first UPS (“Master” or “Number 1” labeled UPS), Inrush circuit breaker (F6) should be in “OFF”/“0” position. (Note: if the UPSs are not factory parallel configured, then any of the UPSs can be switched on but one should be configured as master and the remaining UPSs as slave which will be explained in detail in the following section).
- 6 Go to the “CONFIGURATION” section from the front panel menu, select “MODE” part and check that “PARALLEL-1” name is displayed; otherwise change from “SINGLE” to “PARALLEL-1” name by using the keys. Please check this during commissioning.
- 7 By using DOWN key on the same menu enter to “N NUMBER” part and select “N” number. The Parallel System operate according to redundancy principle.

N is the minimum UPS qty that is required to supply the load where each UPS operates in full load condition. Then (UPS qty) - (N) becomes the redundant UPS qty in the Parallel System.

On each UPS, the value N should be same and correctly entered.

“N” can be defined as 1, 2 or 3.

- 8 After defining the UPS name and N value from the “CONFIGURATION” menu, switch off the UPS and similarly configure the other Parallel UPSs in the Parallel System. After this switch off each UPS again. Maximum 4pcs of UPS can be connected in parallel and each UPS name should be different (note: if the UPSs are factory parallel configured then each UPS name has been already defined, please check and control this).



Configuring the Parallel UPSs with same name may cause serious damage during operation. Make sure that each Parallel UPS is configured with different names.



The UPS shows the condition of “Redundancy Lost” through the “REDUND. LOST” alarm message. “REDUND. LOST” alarm message is just a warning alarm stating that the load amount shared on the remaining UPSs is more now, after the failure of one UPS or after a power increase on the load side. This alarm shall not affect the normal operation of the Parallel System. It indicates that there is not anymore a redundant UPS in the Parallel System. In case of a failure on one of the remaining UPSs, the Parallel System will either go to Overload, Bypass condition or will shut down totally depending on the UPS quantity in the Parallel System.

The following table shows the condition of “Redundancy Lost” for some typical Parallel Systems. Load% is displayed on the LCD display of each UPS.

Total Parallel UPSs quantity	N (minimum UPSs to support the load)	Number of redundant UPSs	Condition of “Redundancy Lost”
2	1	1	Load % > 50%
3	2	1	Load % > 66%
4	3	1	Load % > 75%
4	2	2	Load % > 50%

- 9 After completing the configuration of the name of each UPS and N value, switch on the Input circuit breaker (F1), then Bypass circuit breaker (F4) (if the UPS is split Bypass version) and Inrush circuit breaker (F6) respectively on each Parallel UPS.

After seeing “NORMAL” message on the LCD panel, Battery circuit breaker (F5) can be switched on.

Then the Output circuit breaker (F2) can be switched on accordingly.

The Parallel System (all UPSs in parallel configuration) will start operating from static Bypass initially, and then they will start supplying the load from Inverter.

- 10 The initially started up UPS will operate as master and the remaining UPSs will operate as slave. According the numbers defined for each ups, on the LCD panel, MAS (master) and SLAVE (1, 2, 3, 4) messages should be observed. On the master unit, candidate master UPS is also shown as CX.

CX represents the best available master candidate UPS among the slave UPSs and X represents the number of the slave UPS. In case the master UPS fails, then this candidate assigned UPS becomes master.

6.3 Procedure for Transferring to Static Bypass

In case it is required to transfer the Parallel System to Static Bypass, then this process can be made from the LCD panel of any UPS in the Parallel System. In case static Bypass is activated on any UPS, all the UPSs will pass to Static Bypass mode at the same time.

In order to transfer to static Bypass mode, from the LCD panel menu, go to “COMMANDS” menu and then go to “EXTENDED CMNDS” submenu.

Select “SYS. TO BYP” and confirm “ENBLD” command by pressing ENTER key. If ENTER key is pressed again from any UPS of the Parallel System (does not need to be done from the UPS where it was enabled at the first time), then the selection will be changed to “DSBLD” (Static Bypass disabled, again Inverter operation starts).

6.4 Procedure for Transferring to (Maintenance) Manual Bypass

In case it is required to transfer the Parallel System to Manual Bypass, then this process can be made from any UPS of the Parallel System. In case Manual Bypass is activated on any one of the UPS, all the UPSs will pass to Manual Bypass mode at the same time.

In order to activate the Maintenance Manual Bypass, it is enough to switch on the Maintenance Bypass breaker (F3) on any UPS.

To go back to Inverter operation again, it is necessary to switch off the manual Bypass circuit breaker (F3) of the UPS which was switched to on position in the first place.

6.5 Procedure for Switching OFF

To switch off the Parallel System or one of the UPSs, follow the procedure below;

- 1 Bring the Battery circuit breaker (F5) to “OFF”/“0” position.
- 2 Bring the Output circuit breaker (F2) to “OFF”/“0” position.
- 3 Bring the Input circuit breaker (F1) to “OFF”/“0” position.
- 4 Bring the Inrush circuit breaker (F6) to “OFF”/“0” position.
- 5 Bring the Bypass circuit breaker (F4) to “OFF”/“0” position, if it exists.

Now the UPS or UPSs can be separated from the Parallel System.

7 Features and Operating Limits

7.1 Mains Limits for Normal mode

Frequency and RMS value of the mains input voltage has to be within acceptable limits for the UPS to operate in Normal mode.

Lower limit of the voltage depends on how much the UPS is loaded and it decreases as the load decreases until it reaches 80 VAC Line-Neutral.

Frequency lower and upper limits and voltage upper limit are fixed.

Voltage and frequency ranges for normal operation are given in the “Technical Specifications” section of the manual.

This feature lessens the need to use the batteries. Thus, it increases the battery life and continuity of the load power.

7.2 Bypass Mains Limits for Bypass mode

Frequency, RMS value and total harmonic distortion of the Bypass mains input voltage has to be within acceptable limits for the UPS to operate in Bypass mode.

Different RMS voltage upper and lower limits are present for the return from another operating mode to Bypass mode. This provides hysteresis and ensures that the device does not change operating mode very often when the Bypass mains RMS voltage is close to one of the limits.

Bypass mains limits are software parameters. They can be changed upon request.

7.3 Battery Test

This feature enables the user to obtain information about the battery condition. If the batteries have approached end of their lives, batteries fail.

Battery life depends on several parameters like the number of charge-discharge cycles, discharge depth and ambient temperature. Battery life greatly decreases as the ambient temperature increases. Therefore it is recommended to keep the ambient temperature about 20 °C.

To perform a Battery Test, select “START B. TEST” in the “COMMANDS” menu and push ENTER key.

The Battery Test starts immediately and it finishes after about ten seconds.

If the batteries pass the test, no alarm will be shown.

If the batteries fail, you’ll receive “BATT TS FAIL” alarm message under the “ALR” submenu. In this case, make sure that the Battery circuit breaker (F5) is “ON”/“1”, charge the batteries for minimum 10 hours and repeat the test. If the alarm persists, consult Technical Service for replacement.



Make sure that the batteries are fully charged and Battery circuit breaker (F5) is “ON”/“1” before starting the Battery Test. Otherwise, the batteries will fail even if they are in good condition.

“BATT TS FAIL” alarm message will not disappear until another successful test is performed.

7.4 Overload Behavior

While operating in Normal or Battery mode, the UPS can feed overloads for a limited duration which is given in the “Technical Specifications” section. After that duration, UPS automatically switches into Bypass mode, if the Bypass is enabled and frequency/waveform/RMS value of the Bypass mains voltage is within limits. If the Overload situation continues in the Bypass operation, thermal/magnetic protection devices may activate and protect the circuit. In this case, all loads on the output will be switched off.



Make sure that the UPS is not overloaded to provide a higher quality supply to the loads.

7.5 Electronic Short Circuit Protection

The UPS attempts to force the thermal/magnetic protection devices between the output terminals and the short circuited load to open, by supplying current to the short circuited load for a limited duration. The UPS must be working in Battery or Normal mode, for this feature to work.



To enable the short circuit protection feature of the UPS, each load shall be fed over a separate circuit breaker chosen according to the load current. This should provide quick disconnection of the short circuited load and operation continuity of the other loads. To obtain maximum protection, the rating of each individual load circuit breaker shall have the minimum value, which is enough to carry the full load current continuously.

If the protection device fails to open the circuit in a limited time, the UPS stops feeding current to the output. “VSECFLR” alarm message is shown on the upper left of the LCD.

8 Communication Interfaces

All related terminals are on the Communication Interface board (A1). Connector layout is as following:

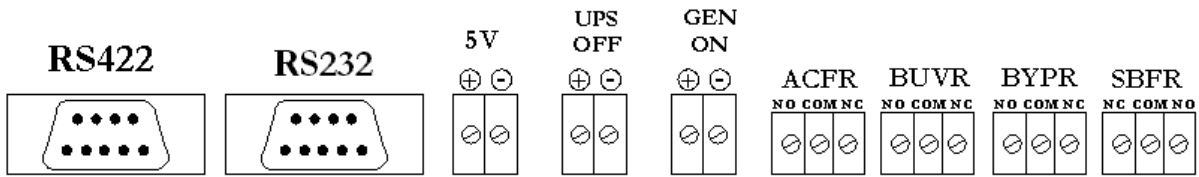

8.1 RS232 Communication

DSUB-9 female connector with the following pin layout shall be used on the UPS side of the connection cable.

Pin layout is given below:

RS232 PIN LAYOUT		
Pin #	Signal Name	Signal Description
2	RX	Receive data
3	TX	Transmit data
5	GND	Signal ground

RS232 cable shall be shielded and shorter than 15 m.

Only one of the RS232/RS422 communications can be activated at one time. The selection between RS232 and RS422 communications can be done by setting the “COMM” parameter in “COMMANDS” menu, as desired.

8.2 RS422 Communication

DSUB-9 male connector with the following pin layout shall be used on the UPS side of the connection cable.

Pin layout is given below:

RS422 PIN LAYOUT		
Pin #	Signal Name	Signal Description
6	A	Receive signal pair
5	B	
1	Z	Transmit signal pair
9	Y	
4	GND	Signal ground

RS422 cable shall be shielded and shorter than 100 m.

Only one of the RS232/RS422 communications can be activated at one time. The selection between RS232 and RS422 communications can be done by setting the “COMM” parameter in “COMMANDS” menu, as desired.

8.3 Digital Inputs (UPS OFF and GEN ON)

Voltage to be applied to the digital inputs is 5 VDC. Maximum current drawn by each input is 1 mA. 5V connector provided on the Communication Interface board can be used to supply both digital inputs.



Pay attention to the polarity of the voltages applied to the digital input terminals.

Input	Function
UPS OFF	If the UPS OFF input is set high by applying 5 VDC voltage on the related terminals, UPS stops generating the output voltage and stops feeding the load. When the voltage on the digital input is removed, the UPS starts up according to the normal procedure.
GEN ON	If the GEN ON input is set high by applying 5 VDC voltage on the related terminals, UPS smoothly increases the current drawn from the generator during transitions from Battery mode to Normal mode.

8.4 Free Contact Communication

Free contact relay connection cables shall have a cross-section of 1.5 mm².



Maximum voltage to be applied to the relay contacts is 42 VAC RMS (sinus) or 60 VDC. Maximum contact current depends on the applied voltage and the load characteristic. Both maximum voltage and maximum contact current corresponding to the applied voltage shall not be exceeded.

Maximum allowed resistive contact currents for several voltages are given on the table below:

Applied voltage	Maximum contact current for resistive load
Up to 42 VAC	16 A
Up to 20 VDC	16 A
30 VDC	6 A
40 VDC	2 A
50 VDC	1 A
60 VDC	0.8 A

Each relay has both a normally open (NO) and a normally closed (NC) contact. One end of these contacts is common. Normal states of the relay contacts are shown on the figure at the beginning of the “Communication Interfaces” section.

Relay functions are described below:

Relay	Function
ACFR (AC Failure Relay)	Contacts change position if the RMS value or frequency of the mains voltage is beyond their limits.
BYPR (Bypass Relay)	Contacts change position if the UPS is working in the Bypass mode.
BUVR (Battery Under Voltage Relay)	Contacts change position if the battery voltages are critically low to feed the load and the load power is about to be interrupted.
SBFR (Secure Bus Failure Relay)	Contacts change position, if the output voltage disappears.

9 Maintenance

Batteries, fans and capacitors shall be replaced at the end of their lives.



Hazardous voltage and high temperature metal parts inside even if the UPS is disconnected. Contact may cause electric shock and burns. All operations except replacing Battery fuses shall be carried out by the authorized technical personnel only.



Some parts inside the UPS (terminals, EMC filters and measurement circuits) are still energized during maintenance Bypass operation. In order to isolate all UPS parts, circuit breakers on mains and Bypass mains distribution panels feeding the UPS and circuit breakers on external battery cabinet shall be brought to “OFF/0” position. Internal batteries shall also be isolated from the system.

9.1 Battery Fuses

Bringing the Battery circuit breaker (F5) to “ON”/“1” position before seeing “NORMAL” message on the LCD may cause Battery fuses to blow out.



Battery fuses shall only be replaced with Gould 22x58 AR 660V ultra fast fuse of same rating or equivalent.

9.2 Battery

Battery life strongly depends on the ambient temperature. There are also other factors like the number of charge-discharge cycles and discharge depth.

Battery life is between 3-10 years if the ambient temperature is between 10 - 20 °C. Performing Battery Test can provide you with information about battery condition. (See “Battery Test” section for more information on Battery Test)



Danger of explosion and fire if the batteries of the wrong type or number are used.



Do not dispose of batteries in a fire. The batteries may explode. Do not open or mutilate batteries. Released electrolyte is harmful to the skin and eyes. It may be toxic.

9.3 Fans

The life of fans used to cool the power circuits depends on the usage and environmental conditions. Preventive replacement by authorized technical personnel every four years is recommended.

9.4 Capacitors

The life of the electrolytic capacitors on the DC bus and the capacitors used for output and input filtering purposes depends on the usage and environmental conditions.

Preventive replacement by authorized technical personnel every five years is recommended.

10 Troubleshooting

This section gives information about the procedures which shall be performed in case of abnormal operation. If you fail to fix the problem consult authorized Technical Service with the following information:

- ▶ Model and serial number of the UPS, which can be found on the nameplate on the rear of the UPS. This information is also available in the test report provided with the UPS.
- ▶ ALR and ST codes in the “ALARMS” menu.



Hazardous voltage and high temperature metal parts inside even if the UPS is disconnected. Contact may cause electric shock and burns. This unit is to be served by authorized technical personnel only.

Alarms and problems you may encounter during operating the UPS are given in the table below.

If you have noticed an abnormality in operation; check the Protective Earth connections, examine the circuit breakers positions, read alarms from the “ALARMS” menu and refer to the table. Apply all suggestions corresponding to each alarm. If your issue is excluded or the suggested actions do not solve your problem, consult the Technical Service.

Alarm	Possible Cause	Action to solve
BYP BADSHAPE	Bypass mains voltage is different than the Inverter reference signal (e.g. its frequency is beyond synchronization limits or it has a total harmonic distortion > 10%).	Make sure that the Bypass circuit breaker is “ON”/“1” (if the UPS has no separate Bypass mains input, make sure that the Input circuit breaker is “ON”/“1”).
BYP VOL HIGH	Bypass mains voltage is higher than its upper limit.	Check if the Bypass mains voltage is in specified limits.
BYP VOL LOW	Bypass mains voltage is lower higher than its lower limit.	
BYP SYN FAIL	Frequency of Bypass mains voltage is beyond the frequency range for Bypass operation or Bypass mains voltage is very low.	
BYP SEQ FAIL	Phase sequence of Bypass mains voltages is not OK.	Phase sequence of the separate Bypass mains input shall be changed. Consult Technical Service.
MNBYP SW ON	Manual Bypass circuit breaker is “ON”/“1”.	Check the position of the manual Bypass circuit breaker.
INV TMP HIGH	Inverter temperature is very high.	-Check if there is an Overload and remove the excessive load. -Measure the ambient temperature near UPS. -Make sure that the temperature is in specified limits. -Check if the fans are running.
OUT OVERLOAD	RMS current drawn from any of the output lines exceeds its nominal value.	-Check if there is an Overload and remove the excessive load. -If the total power drawn by the load is less than the nominal power, make sure that it is distributed evenly between phases.
INV BLCK	Inverter operation is automatically stopped due to a fault.	Consult Technical Service.

Alarm	Possible Cause	Action to solve
VSEC NOT OK	The UPS may not start up yet. This alarm is permanent if the UPS is intended to be started with the Bypass blocked or when the Bypass mains is not in specified limits.	<ul style="list-style-type: none"> -Make sure that all circuit breakers are "ON"/"1". -Check if there is any other alarms and apply the related suggestions -Examine the preferences, check the mains voltages -Read the "Operating Modes" section of the manual. -Determine if the combination of line voltages and preferences does inhibit the UPS operation.
	The UPS may have stopped to feed the load because the combination of the mains conditions and the user preferences made from the "COMMANDS" menu does not allow the UPS to work in any of the operating modes (e.g. if Inverter is disabled and both input and Bypass mains voltages are not acceptable or if the Rectifier is disabled when the Bypass voltage is not in specified limits or batteries are discharged during a prolonged outage).	
	The Output circuit breaker is "OFF"/"0".	
INP VOL HIGH	Input Line/Neutral voltage is higher than its upper limit.	Check if the mains voltage is in specified limits.
INP VOL LOW	Input Line/Neutral voltage is lower than its lower limit.	
INP SYN FAIL	Frequency of mains voltage is beyond the frequency range for normal operation or mains voltage is very low.	Check if the mains voltage is in specified limits.
INP SEQ FAIL	Phase sequence of input mains voltages is not OK.	Phase sequence of the mains input shall be changed. Consult Technical Service.
REC TMP HIGH	Rectifier temperature is very high.	<ul style="list-style-type: none"> -Measure the ambient temperature near UPS. -Make sure that the temperature is in specified limits. -Check if the fans are running.
REC OVERLOAD	RMS current drawn from any of the input lines exceeds its nominal value.	Check if there is an Overload and remove the excessive load.
VDC HIGH	Any of the DC bus voltages is higher than its upper limit.	Consult Technical Service.
VDC LOW	Any of the DC bus voltages is lower than its lower limit Means that the batteries had discharged. It is removed when the Rectifier resets.	If you encounter this alarm during start-up, check if the Inrush circuit breaker is "ON"/"1".
		Charge the batteries, perform Battery Test and check if the alarm has removed.
REC BLCK	Rectifier operation is automatically stopped due to a fault.	Consult Technical Service.

Alarm	Possible Cause	Action to solve
VDC NOT OK	Any of the DC bus voltages approaches its lower/upper limits. May mean that the batteries have approached to their lower voltage limit and are almost empty.	Charge the batteries, and check if the alarm has removed.
T-AMB HIGH	Ambient temperature exceeds its upper limit.	-Measure the ambient temperature near UPS. -Make sure that the temperature is in specified limits.
GENSET ON	“Generator Friendly” operation is activated (digital input “GEN ON” is set high).	Check the “GEN ON” input.
EMG STOP ON	Emergency stop is activated (digital input “UPS OFF” is set high).	Check the “UPS OFF” input.
BATT TS FAIL	Batteries failed in the Battery Test.	-Perform the test again when the batteries have been charged for a long time and the Battery circuit breaker is “ON”/“1”. -Check if the alarm continues.
BATT CR OPEN	Battery circuit breaker (F5) is probably open (“OFF”/“0”).	-Make sure that the Battery circuit breaker is “ON”/“1”. If not do the following: -Check the Rectifier preference and enable the Rectifier. -Make sure that the input mains voltage is in specified limits. -Make sure that the UPS has switched to Normal mode and close the Battery circuit breaker.
	The Battery circuit breaker of the external battery cabinet is open (“OFF”/“0”).	-Make sure that the Battery circuit breaker of the external battery cabinet is “ON”/“1”. If not do the following: -Check the Rectifier preference and enable the Rectifier. -Make sure that the input mains voltage is in specified limits. -Make sure that the UPS has switched to Normal mode and close the Battery circuit breaker.
	Battery fuses of the Battery circuit breaker (F5) or the external battery cabinet may have blown.	Check if the Battery fuses are blown. Replace if necessary (see maintenance section).
	There is no battery in the system.	Batteries shall be supplemented. Consult Technical Service.

11 Technical Specifications

EVO DSP TT MODELS									
Rating [kVA]	10	15	20	30	40	60	80	100	
ENVIRONMENTAL									
Storage temperature range	-25°C to +55°C (15°C - 40°C recommended for longer battery life)								
Operating temperature range	0°C to +40°C (20°C - 25°C recommended for longer battery life)								
Relative humidity range	0% - 95% (non condensing)								
Max. altitude without derating [m]	1000								
Protection level	IP 20								
Maximum power dissipation	[W]	800	960	1280	1920	2560	3840	5120	6400
	[Btu]	2730	3277	4369	6553	8737	13106	17475	21843
	[kcal/h]	688	825	1100	1650	2200	3302	4403	5503
ELECTRICAL									
Mains Input									
Number of phases	3 Phases + Neutral								
Nominal voltage [V]	380 / 400 / 415 (Line-Line)								
Voltage range for Normal mode (Line-Neutral) [V]	Lower limit	187 (Line-Neutral; at 100% load)							
		120 (Line-Neutral; at 64% load)							
		80 (Line-Neutral; at 42% load)							
	Upper limit	280 (Line-Neutral)							
Nominal frequency [Hz]	50 / 60								
Frequency range [Hz]	+/-10%								
Nominal current [A]	waveform	sinusoidal							
	RMS value *(Note 2)	13	20	26	40	53	79	105	131
Maximum current [A]	waveform	sinusoidal							
	RMS value	17	23	30	47	61	95	125	158
Output									
Performance classification according to IEC 62040-3	VFI-SS-111								
Number of phases	3 Phases + Neutral								
Nominal voltage [V]	380 / 400 / 415 (Line-Line)								
Static voltage regulation at %100 linear load	Normal mode	< 1%							
	Normal mode								
Nominal frequency [Hz]	50 / 60								
Free running frequency [Hz]	± 0,01%								
Total Harmonic Distortion (THD) at rated linear load	< 3%								
Nominal power [kVA]	10	15	20	30	40	60	80	100	
Maximum load Power Factor	0.8								
Nominal active power [kW]	8	12	16	24	32	48	64	80	
Nominal current [A] at 380V	15.2	22.7	30.3	45.5	60.6	91	121	151	
Load crest factor at rated power	3:1								
Overload duration	> 1 min at 150% load								
Efficiency (Normal mode) at rated linear load (Power Factor = 0.8)	> 92%								

Static Bypass								
Number of phases	3 Phases + Neutral							
Voltage range (Line-Neutral) [V] *(Note 1)	220 / 230 / 240 ± 10% (Line-Neutral)							
Frequency range [Hz] *(Note 1)	47-53							
Nominal power [kVA]	10	15	20	30	40	60	80	100
Nominal current [A]	15.2	22.7	30.3	45.5	60.6	91	121	151
Transfer duration [ms]	0							
BATTERIES								
Battery type	Lead acid, Sealed, Free Maintenance, 12Vdc							
Number of batteries	2 x 31							
Nominal battery voltage [Vdc]	2 x 372							
Stored energy time with nominal load *(Note 2)	Battery 7Ah	20 min	15 min	10 min	-	-		
	Battery 9Ah	30 min	20 min	15 min	7 min	-		
STANDARDS								
Safety	EN 62040-1-2, EN 60950-1							
Performance	EN 62040-3							
EMC	EN 62040-2							
Product Certification	CE							
COMMUNICATIONS								
Free contact communication (AC failure, battery under voltage, Bypass and output failure)								
Serial communications (RS232, RS422)								
Two digital inputs for remote shut down of the UPS and generator operation feedback								
Isolated auxiliary 5V supply for digital inputs								
Interface (Simple Network Management Protocol) - optional								
OTHERS								
Manual Bypass with 0 transfer time								
Electronic short circuit protection								
Over temperature and over current protection								
Liquid Crystal Display (LCD)								
Mimic front panel								
Parallel Redundant operating mode up to 4 UPSs (only if the UPS is factory predisposed to operate in Parallel System)								

*(Note 1): these are software parameters. They can be changed upon request.

*(Note 2): batteries should be fully charged in order to provide these values.

LEAD BATTERIES

EVO DSP TT models utilize lead acid, sealed, maintenance free batteries.

This kind of batteries, if handled by non-experienced personnel, can cause electric shock or short circuit.

For this reason the batteries can be removed only by qualified technical personnel, specialized and authorized by Tecnoware.

Tecnoware declines any responsibilities if this rule is not followed.

The batteries cannot be disposed as an urban waste, but must be treated in conformity with 2006/66/CE European Directive; any violation is indictable with financial sanctions as established into 2006/66/CE European Directive.



12 Internal Battery Location - Connection Instructions

- 1) Take out all the drawers outside of the UPS.
- 2) Place the batteries of the drawer-1 vertically as shown in the drawing. Make the cable link connections between 42nd battery to 48th battery. Then connect the 80 cm cable to the positive pole of the 42nd battery. Insert the drawer to the bottom shelf and place it on the right side where the poles of the batteries face outside as shown in the diagram.
- 3) Place the batteries of the drawer-2 vertically as shown in the drawing. Make the cable link connection between 56th battery to 62nd battery. Insert the drawer to the bottom shelf and place it on the left side where the poles of the batteries face outside as shown in the diagram.
- 4) Place the batteries of the drawer-3 horizontally as shown in the drawing. Make the cable link connection between 49th battery to 55th battery. Then connect the 80 cm cable to the negative pole of the 55th battery. Connect and fix the battery holder metal sheet to the drawer. Insert the drawer to the bottom shelf and place it in the middle of drawers 1 and 2.
- 5) Make the connection between 55th and 56th batteries with 80 cm cable.
- 6) Place the batteries of the drawer-4 vertically as shown in the drawing. Make the cable link connections between 22nd battery to 28th battery. Then connect the 80 cm cable to the positive pole of the 22nd. Insert the drawer to the middle shelf and place it on the right side where the poles of the batteries face outside as shown in the diagram.
- 7) Place the batteries of the drawer-5 vertically as shown in the drawing. Make the cable link connections between 35th battery to 41st battery. Insert the drawer to the middle shelf and place it on the left side where the poles of the batteries face outside as shown in the diagram.
- 8) Place the batteries of the drawer-6 horizontally as shown in the drawing. Make the cable link connection between 29th battery to 31st and between 32nd to 34th battery as show in the drawing. Then connect the positive blue neutral (N) cable to 32nd battery and negative blue neutral (N) cable to 31st battery. These are the middle points of battery pack. Then connect the 80 cm cable to the negative pole of the 34th battery. Connect and fix the battery holder metal sheet to the drawer. Insert the drawer to the middle shelf and place it in the middle of drawers 4 and 5.
- 9) Make the connection between 34th and 35th batteries with 80 cm cable.
- 10) Place the batteries of the drawer-7 vertically as shown in the drawing. Make the cable link connections between 1st battery to 7th battery. Insert the drawer to the upper shelf and place it on the left side where the poles of the batteries face outside as shown in the diagram. Connect the red battery (B+) cable to the positive pole of the 1st battery.
- 11) Place the batteries of the drawer-8 vertically as shown in the drawing. Make the cable link connections between 15th battery to 21st battery. Insert the drawer to the upper shelf and place it on the left side where the poles of the batteries face outside as shown in the diagram.
- 12) Place the batteries of the drawer-9 horizontally as shown in the drawing. Make the cable link connection between 8th to 14th batteries. Then connect the 80 cm cable to the negative pole of the 14th battery. Connect and fix the battery holder metal sheet to the drawer. Insert the drawer to the upper shelf and place it in the middle of drawers 7 and 8.
- 13) Make the connection between 14th and 15th batteries with the 80 cm cable. Connect the black battery (B-) cable to the negative pole of the 62nd battery.
- 14) Make the connection between 21st and 22nd batteries with the 80 cm cable. Make the connection between 41st and 42nd batteries with the 80 cm cable.
- 15) Make the connection between A point (negative pole of 7th battery) and B point (positive pole of 8th battery) as explained in the section "Internal Battery Connection) through the 40 cm cable.
- 16) Make the connection between C point (negative pole of 28th battery) and D point (positive pole of 29th battery) as explained in the section "Internal Battery Connection) through the 40 cm cable.
- 17) Make the connection between E point (negative pole of 48th battery) and F point (positive pole of 49th battery) as explained in the section "Internal Battery Connection) through the 40 cm cable.

- 18) Check the battery voltage between (N) and (B-) terminals (correct voltage is ~372 VDC), (B+) and (N) terminals (correct voltage is ~372 VDC), (B+) and (B-) (correct voltage is ~744 VDC).



PAY ATTENTION: if you buy an UPS without batteries (/00 version) and install the batteries individually, pay attention to the following instruction:

- Stick a rubber thickness in every battery drawer (see the point A below). You can it in the UPS accessories.

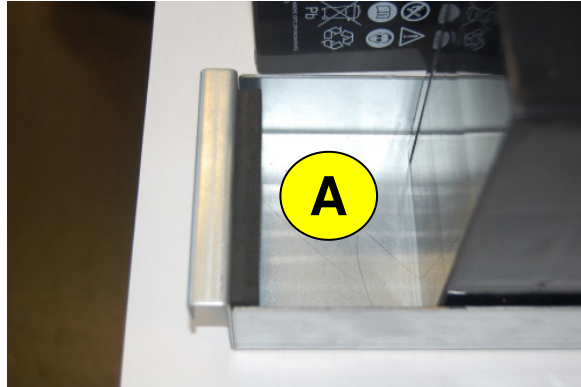

- Stick two thicknesses for every UPS side (see the point B and C below). You can find them in the UPS accessories.

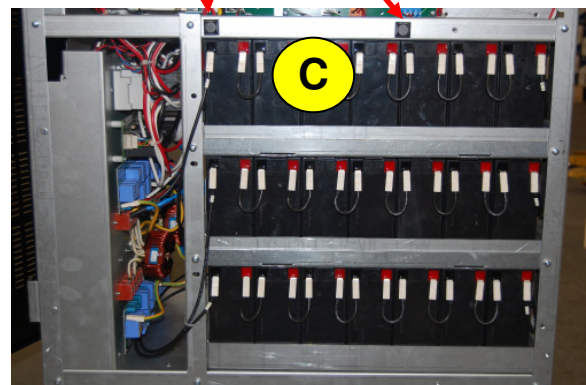
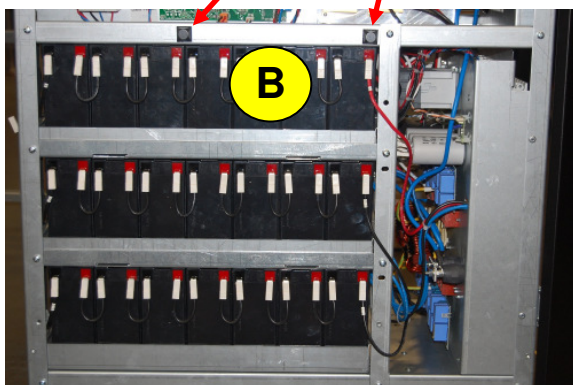
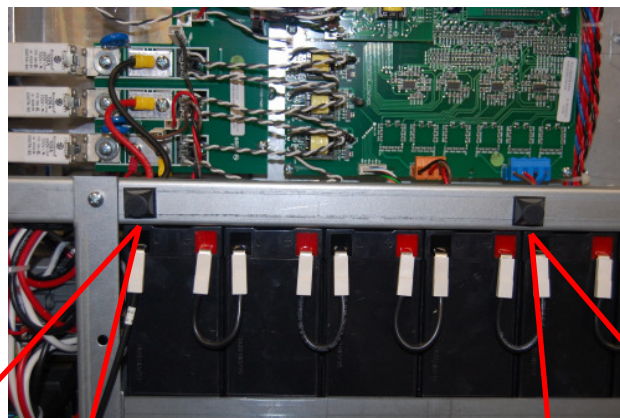



TECNOWARE S.r.l.

www.tecnoware.com