



DST-24B/PCI

DST-24B/PCI+

DST-24B/PCI(2.0)

DST-24B/PCI+(2.0)

DST-24B/PCle(2.0)

DST-24B/PCle+(2.0)

Digital Station Tap Board

Hardware Manual

Version 2.0

Synway Information Engineering Co., Ltd
www.synway.net

Contents

| | |
|--|------------|
| Contents | i |
| Copyright Declaration | ii |
| Revision History | iii |
| Chapter 1 Overview | 1 |
| 1.1 Functions..... | 1 |
| 1.2 Features | 1 |
| 1.3 Advantages (vs. A-type Boards) | 4 |
| 1.4 Operation Principle | 4 |
| 1.5 Functional Modules | 5 |
| Chapter 2 Installation | 6 |
| 2.1 Hardware Structure | 6 |
| 2.2 System Requirements | 11 |
| 2.3 Installation Procedure..... | 11 |
| Appendix A Technical Specifications | 17 |
| Appendix B Technical/sales Support | 18 |

Copyright Declaration

All rights reserved; no part of this document may be reproduced or transmitted in any form or by any means, electronic or mechanical, without prior written permission from Synway Information Engineering Co., Ltd (hereinafter referred to as 'Synway').

Synway reserves all rights to modify this document without prior notice. Please contact Synway for the latest version of this document before placing an order.

Synway has made every effort to ensure the accuracy of this document but does not guarantee the absence of errors. Moreover, Synway assumes no responsibility in obtaining permission and authorization of any third party patent, copyright or product involved in relation to the use of this document.

Revision History

| Version | Date | Comments |
|-------------|---------|--|
| Version 1.0 | 2008-10 | Initial publication |
| Version 1.1 | 2009-5 | New revision |
| Version 2.0 | 2010.5 | Add description on new board models DST-24B/PCI(2.0) and DST-24B/PCI+(2.0). |
| | | |

Note: Please visit our website <http://www.synway.net> to obtain the latest version of this document.

Chapter 1 Overview

The DST Series DST-24B/PCI, DST-24B/PCI+, DST-24B/PCI(2.0), DST-24B/PCI+(2.0), DST-24B/PCle(2.0) and DST-24B/PCle+(2.0) are 24-channel digital station tap boards with PCI/PCle bus, used especially for recording of digital subscriber lines (extension lines).

1.1 Functions

- High-impedance recording of digital phone lines through parallel connection
- A variety of ways to start/stop recording
- Supports simultaneous recording on 24 channels, each with a different format
- Supports independent-recording of incoming, outgoing and mixed-recording modes
- ANI and DNIS support
- Synchronous acquisition of the information displayed on digital phones during recording
- Detects all modes of keying supported by user phones
- Activity/silence detection
- Automatic Gain Control (AGC) support in recording operation
- Call progress monitoring
- Automatically checks board to see if modules are correctly inserted and to determine the number of modules on the board
- Supports detection and alarming of line faults, including line break and errors in voltage level, signal-to-noise ratio and synchronization
- Switches flexibly between voice channels B1 and B2
- Besides, DST-24B/PCI+, DST-24B/PCI+(2.0) and DST-24B/PCle+(2.0) boards support MS-GSM, G.729A and MP3 for encoding in hardware

1.2 Features

- **PCI 2.2 Bus Support**

(DST-24B/PCI & DST-24B/PCI+ & DST-24B/PCI(2.0) & DST-24B/PCI+(2.0))

These four boards include PCI 2.2 bus with burst data transmission rate up to 132 MB/s; the PNP (plug and play) feature they have eliminates the need for jumper leads; in the universal PCI design, they support 3.3V/5V slot voltage and PCI-X.

- **PCle Bus Support**

(DST-24B/PCIe(2.0) & DST-24B/PCIe+(2.0))

Developed with the design of PCIe X1, these two boards support PCIe X1, X2, X4, X8 and X16 slots.

- **DMA Transfer Support**

The DMA transfer of recording data does not cost any of the host CPU resources, which helps extend the capacity of recording lines on a single board to an extreme.

- **Modularized Design**

This board is designed with modularized structure and can be configured in flexible ways. Besides the 8 on-board recording channels, each board can be fitted with up to 2 recording modules, and each module can support recording of up to 8 digital phone lines. Now it is widely used in various systems.

- **Available RJ21 Connector**

This board has a 50-pin RJ21 connector which is often used for PBXs, making connection easy and malfunctions rare. With the help of a 24-port RJ21-to-RJ11 adapter that is supplied with the board, users can use the RJ11 jack for direct connection.

- **Fits Modules via Inter-plane Connectors**

The use of high-precision, streamlined, inter-plane connectors highlights the characteristic compact and highly-reliable advantage of Synway's all-in-one boards.

- **1 to 24 Port Hi-Z Monitoring of Digital Lines**

This board connects to monitored phone lines via high-impedance and parallel connection of 2 or 4-lead lines, with the access points flexibly positioned on communication lines between a digital PBX and some digital phones. In such way, it is widely used for recording multiple digital PBX and phone models.

- **Programmable Tone Detector**

Detects single or dual tones at any frequency, offering facility for use with a variety of PBXs and key telephone systems.

- **Recording of Source Code Stream**

When using the board, any problem found on the monitored line can be located and settled by remote debugging with the cooperation of users.

- **Remote Support for New PBX Models**

New PBX models can be supported by remote operation, not requiring on-site helps.

- **High-impedance Recording**

The recording impedance is over 1KΩ AC, ruling out interruption on transmission

of monitored signals.

- **Instantly-upgradeable Hardware Circuit**

Using instantly-upgradeable hardware circuits, the board can support different models of PBXs and digital phones simply through software reconfiguration, i.e. there is no need to replace any hardware components. So far, a dozen of mainstream PBXs, such as Alcatel, Avaya, NEC, Siemens, Nortel, are supported.

- **Voice Processing & Signaling Analysis**

A single board is capable of processing voices and handling call-signaling analysis, and can constitute a recording system by itself without the need for supplementary boards or external devices.

- **Various CODECs Support**

Offers a large selection of voice CODECs, including hardware-based A-Law (G.711), μ -Law, IMA-ADPCM, and software-based 16-bit linear PCM, MP3. In addition, the DST-24B/PCI+, DST-24B/PCI+(2.0) and DST-24B/PCle+(2.0) boards support hardware-based MP3, MS-GSM and G.729A for encoding.

- **Supports WAV File**

The recorded voice files can be edited and played by audio tools such as Cooledit.

- **Audio Output Interface**

Equipped with an analog tone amplifier circuit and an output interface, the first channel on the board can directly connect to the headset or sound box, allowing monitoring of a specified channel in real time and voice playback only via a simple function call.

- **Unique Hardware Serial Number**

Each board has a unique hardware serial number written in the firmware to distinguish itself from other boards and prevent piracy. The number is available via an easy function call with applications.

- **Authorization Code Identification Circuit**

The on-board authorization code identification circuit is designed for software safety. Users can apply to our company for the authorization code.

- **Synway's Unified SynCTI Driver Development Platform**

Synway owns the intellectual property rights for the unified high-intelligence SynCTI driver development platform. Each system supports up to 2048 channels. Functions such as the detection and analysis of rings, tones and Caller IDs, are available via simple function calls on the driver platform, without having to understand complex call procedures.

1.3 Advantages (vs. A-type Boards)

Compared with the old A-type boards (e.g. SHR-16DA-CT/PCI, SHR-24DA-CT/PCI), the DST-24B/PCI, DST-24B/PCI+, DST-24B/PCI(2.0), DST-24B/PCI+(2.0), DST-24B/PCle(2.0) and DST-24B/PCle+(2.0) boards (hereinafter referred to as B-type boards) are endowed with the following advantages:

- Enabled to perform digital adjustment of front-end analog circuits in software, to optimize the input signals before they come into the processor.
- Enhanced capability to detect line faults.
- Use of FPGA chip, to improve the ability of handling complex signals.
- DMA support, to minimize the CPU cost for data transfer.
- Enabled to record on-line source code streams, to locate problems as soon as possible with the cooperation of users.
- Support of new PBX models through remote debugging.
- Enabled to configure a monitored voice channel to B1 or B2 in software, provided the monitored signal is 2B+D.
- For boards having greater power (e.g. DST-24B/PCI+, DST-24B/PCI+(2.0) and DST-24B/PCle+(2.0)): Support of GSM (by default), G.729A and MP3 (by modifying driver configuration items) compressions.

PS: A-type boards don't support GSM and MP3 compressions.

1.4 Operation Principle

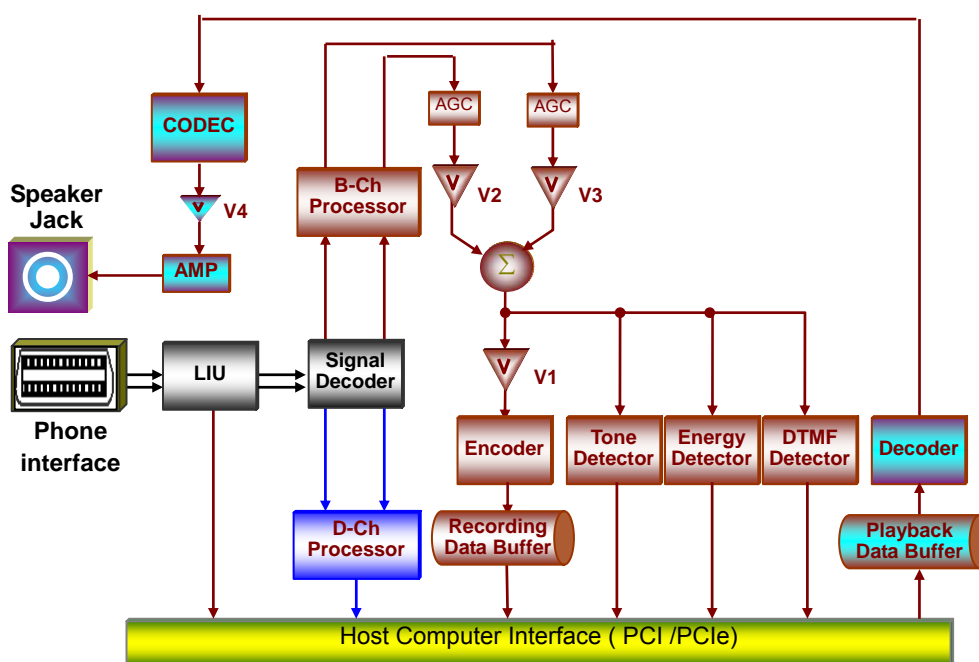

Figure 1-1 Operation Principle

1.5 Functional Modules

- **MOD-24DB High-impedance Recording Module**

This module embraces 8 ports for recording digital phone lines (See Figure 2-10, Figure 2-11). A board, allowed to have up to 2 modules, is able to identify the number of on-board modules. Together with the board's firmware-loading feature, this module can be used to perform recording of most digital PBXs and telephones connected via parallel lines.

Chapter 2 Installation

2.1 Hardware Structure

- DST-24B/PCI, DST-24B/PCI+ Boards

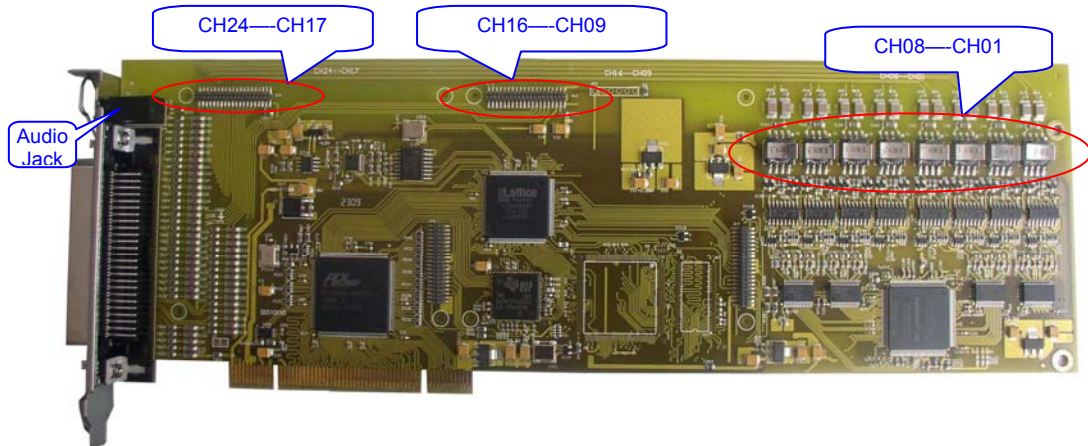

Figure 2-1 DST-24B/PCI (Front View)

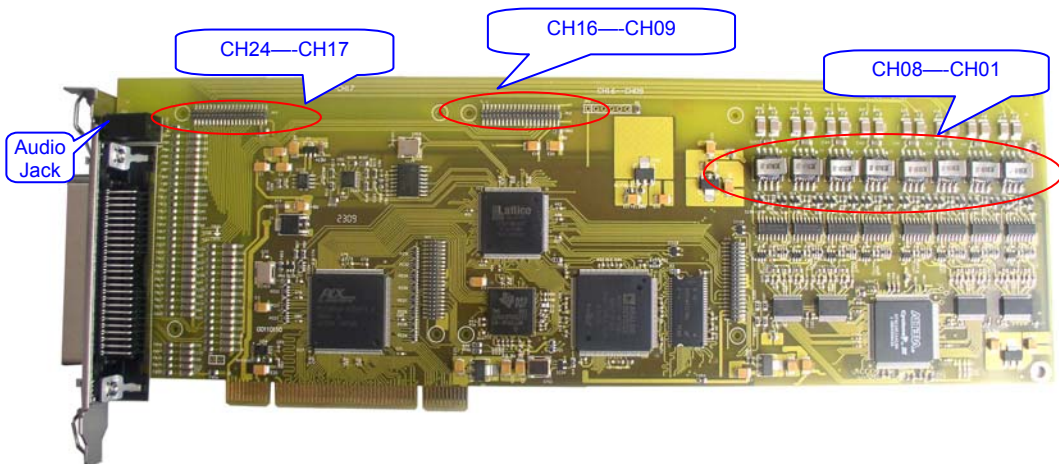

Figure 2-2 DST-24B/PCI+ (Front View)

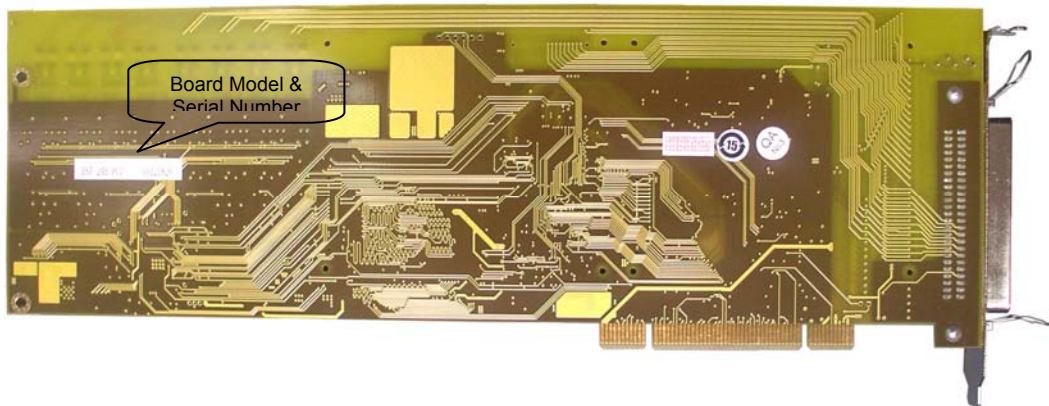

Figure 2-3 DST-24B/PCI, DST-24B/PCI+ (Rear View)

- **DST-24B/PCI(2.0), DST-24B/PCI+(2.0) Boards**

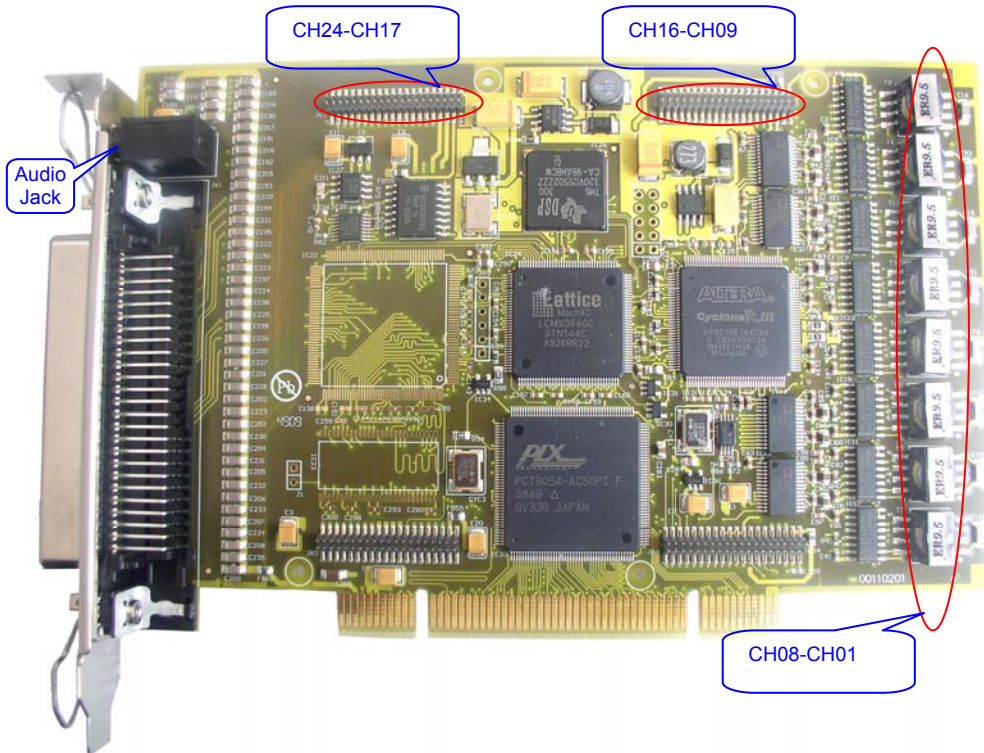

Figure 2-4 DST-24B/PCI(2.0) (Front View)

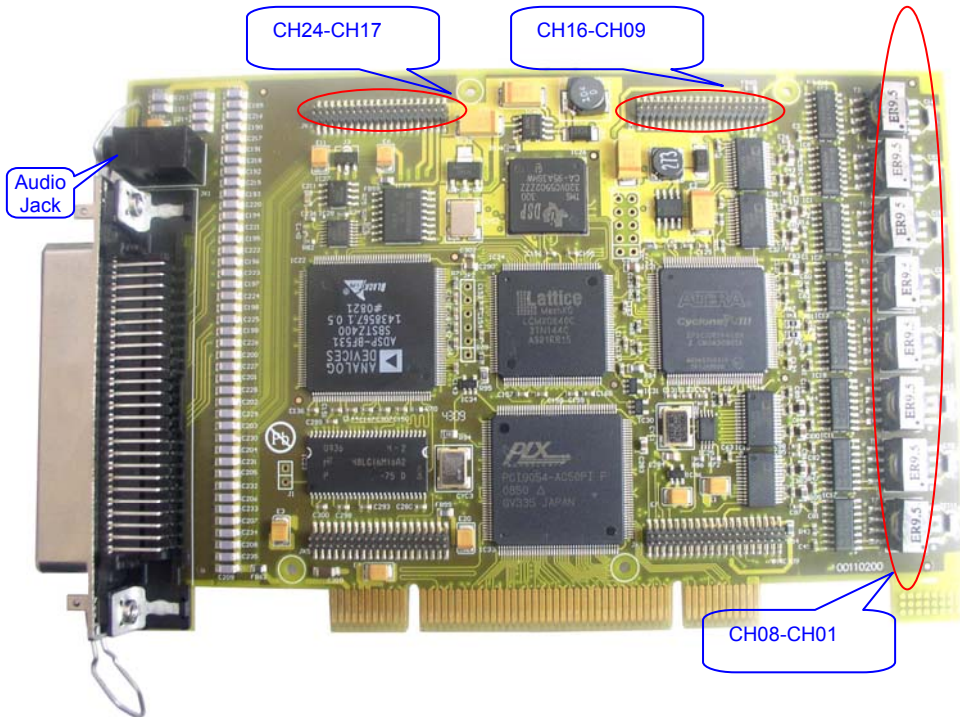

Figure 2-5 DST-24B/PCI+(2.0) (Front View)

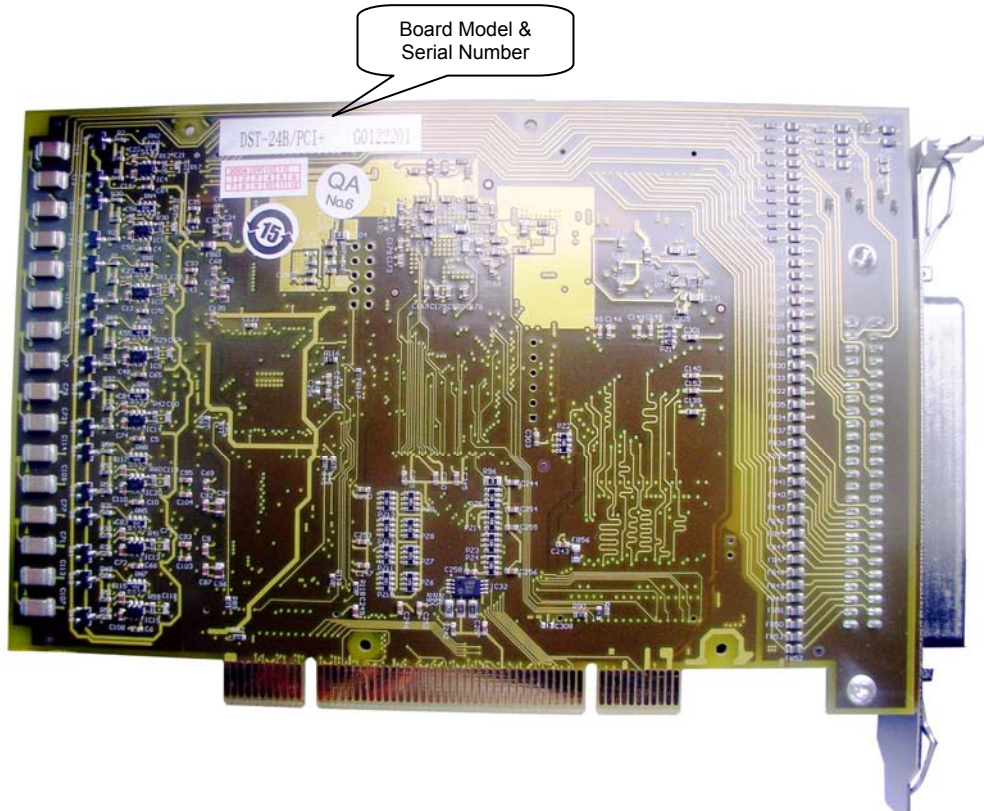

Figure 2-6 DST-24B/PCI(2.0), DST-24B/PCI+(2.0) (Rear View)

- **DST-24B/PCle(2.0), DST-24B/PCle+(2.0) Boards**

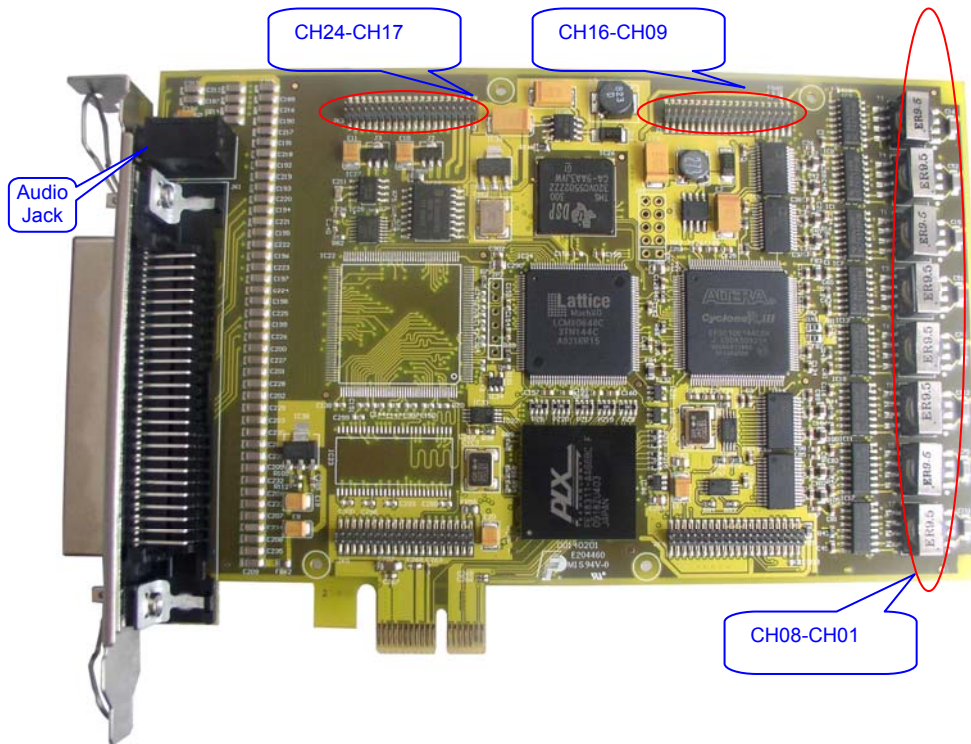

Figure 2-7 DST-24B/PCle(2.0)(Front View)

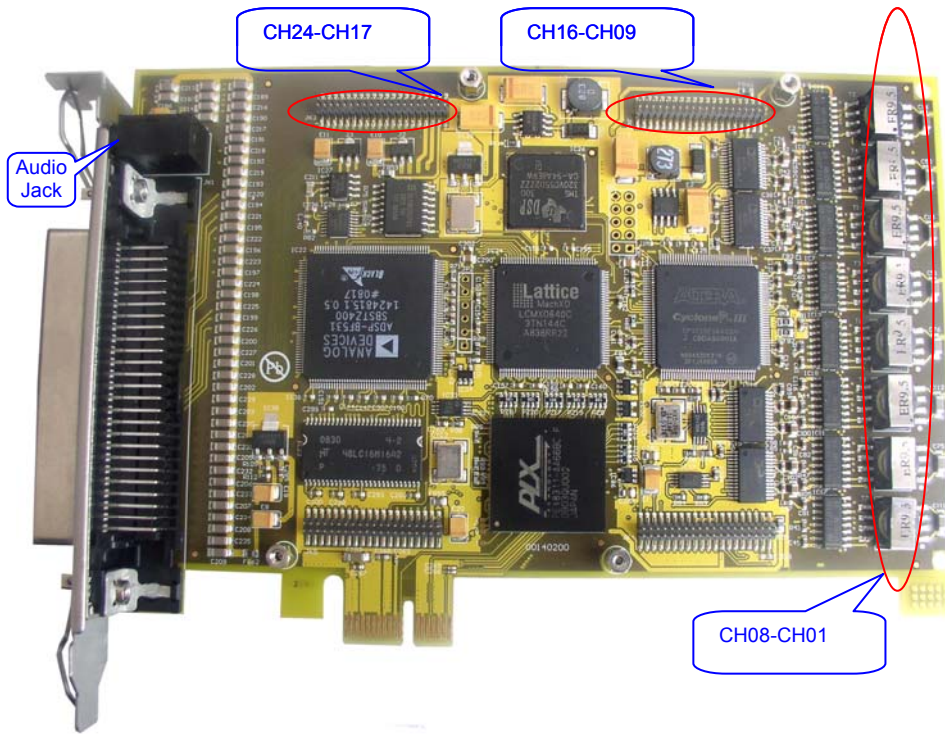

Figure 2-8 DST-24B/PCIe+(2.0) (Front View)

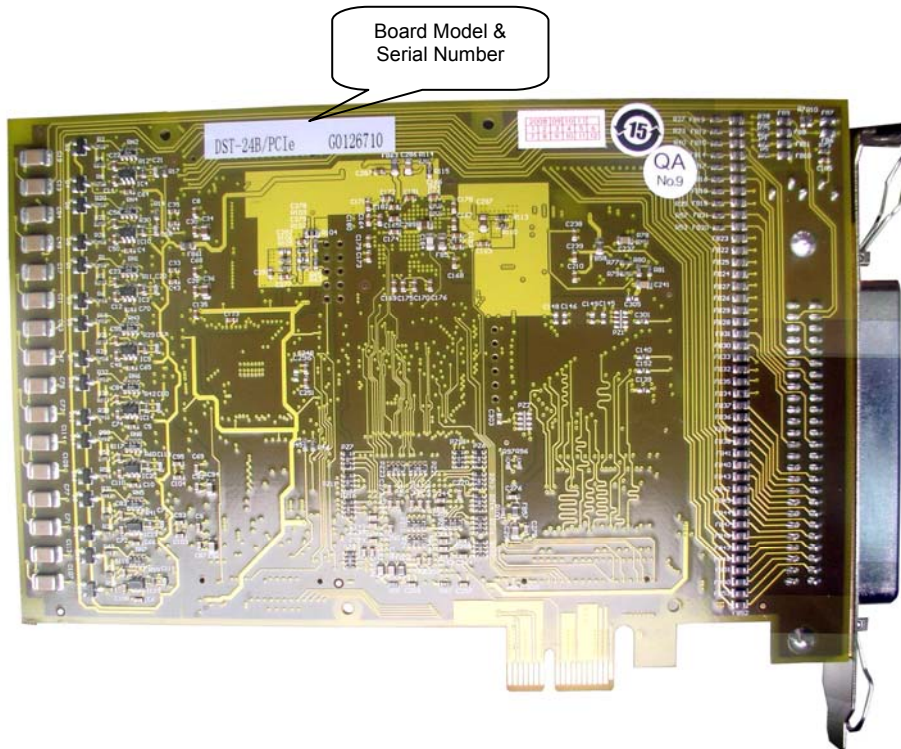

Figure 2-9 DST-24B/PCIe(2.0), DST-24B/PCIe+(2.0) (Rear View)

- MOD-24DB High-impedance Recording Module

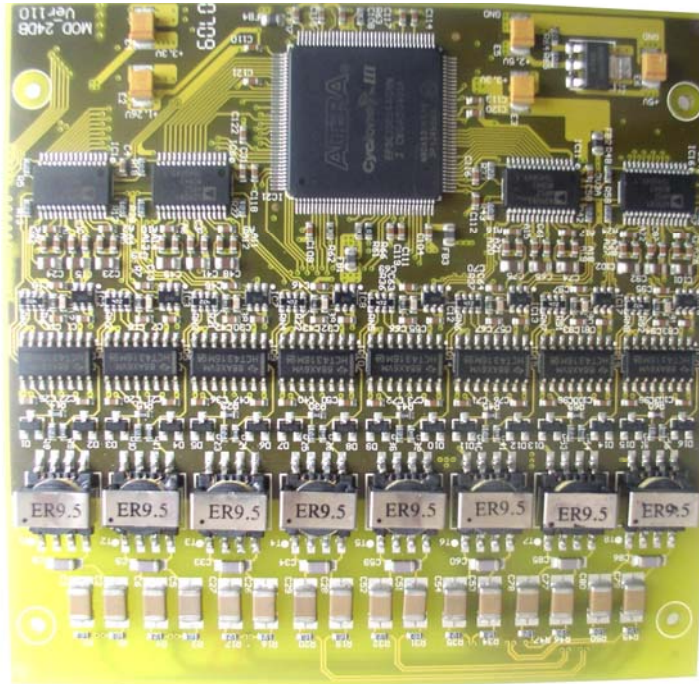

Figure 2-10 MOD-24DB (Version 1.10)

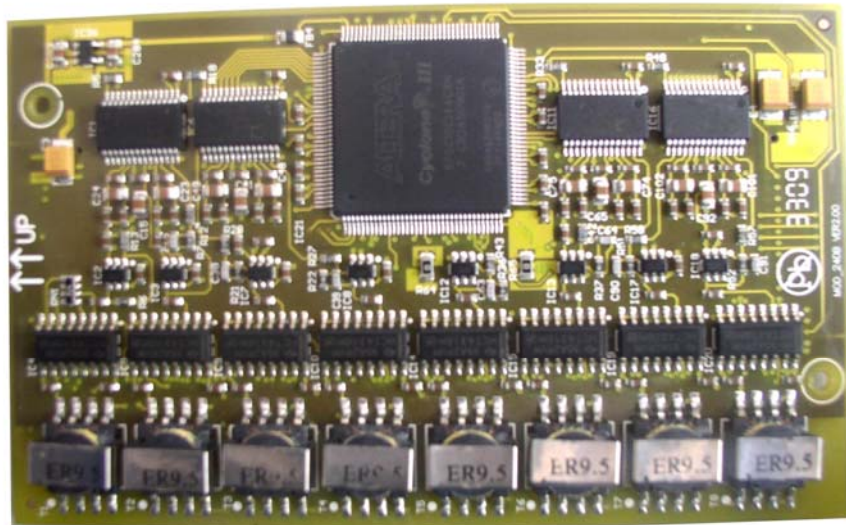

Figure 2-11 MOD-24DB (Version 2.00)

- **Interface description:** The physical pin layout of the on-board RJ-21 connector is shown in Figure 2-12. Chn-a and Chn-b are a pair of phone lines, and an RJ-21 connector can connect with 24 pairs of phone lines at a same time.

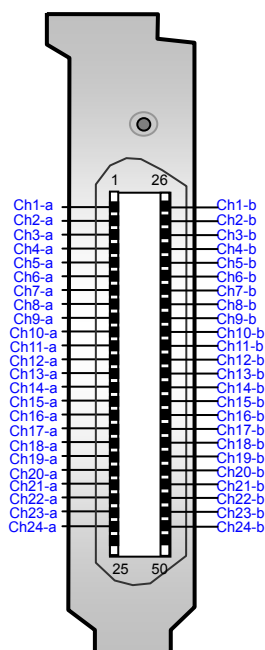

Figure 2-12

2.2 System Requirements

Host System Requirements

CPU: 300MHz Intel® Pentium® II or above

Memory: 256M or more

HD: Depends on individual requirements

Supported Operating Systems

- ✓ Windows 2000/2003/XP
- ✓ Linux RH7.2/RH9.0/AS4/FC4/SUSE10

2.3 Installation Procedure

Note: Always turn off the power before installation!

Step 1: Properly fit the required module(s) into the on-board module slot and then install the board onto the PC chassis.

Step 2: Connect the board to digital phone lines.

In parallel, connect one end of the phone line to a point on the communication line between the PBX and a digital phone, and the other end to the on-board RJ21 connector or to the RJ21-to-RJ11 adapter linked with the board.

Interface description:

The DST-24B/PCI or DST-24B/PCI+ digital station tap board has a 50-pin RJ21 connector (often used for PBXs), which can be converted into twenty-four 2-pin RJ11 jacks through an RJ21-to-RJ11 adapter. See Figure 2-12 above for the physical layout of the connector.

Notes on Connection:

- ① In case of connection with RJ11 jacks, our company provides an RJ21 connecting line and an RJ21-to-RJ11 adapter and recommends the following connection methods:

Method 1:

Connection by 2-lead lines: See Figure 2-13 below. Connect the 2-lead line to the middle 2 pins of each jack which correspond to one channel. Note that the outer 2 pins of each jack cannot be used for connection in this case.

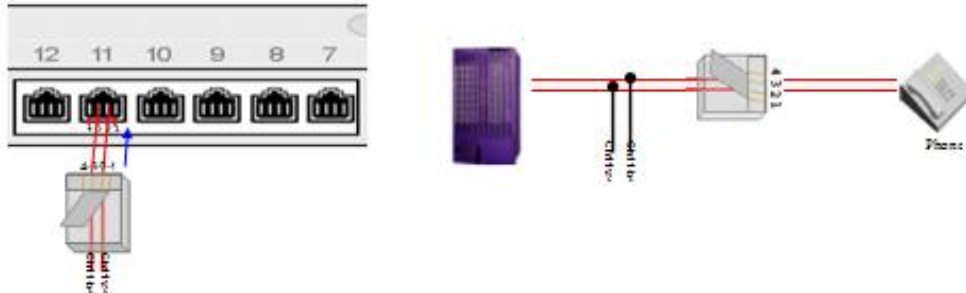

Figure 2-13

However, the Panasonic PBX makes an exception. It requires the access point for parallel connection at the outer two pins of the transmission line, as shown in Figure 2-14 below.

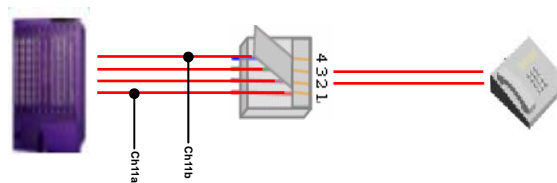

Figure 2-14

Method 2:

Connection by 4-lead lines: Directly insert the phone lines into odd-numbered RJ11 jacks on the RJ21-to-RJ11 adapter. See below for details.

- 1) eON and AVAYA-4W digital phones: See Figure 2-15 below. In parallel, connect the 1st and 2nd leads of the communication line between the PBX and a phone to the 1st and 4th pins of each odd-numbered RJ11 jack on the adapter, and the 3rd and 6th leads to the 2nd and 3rd pins.

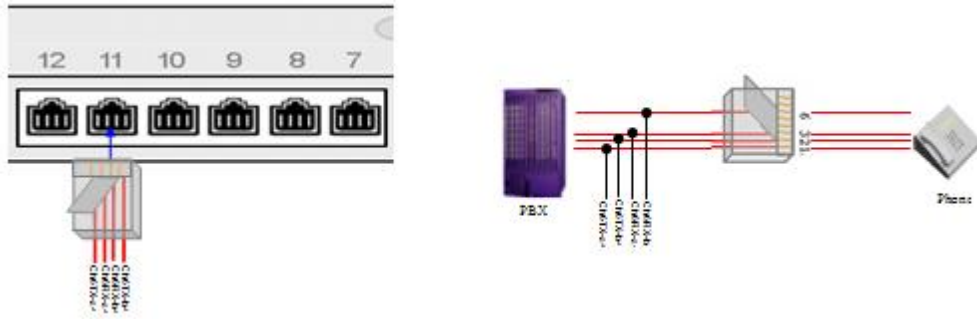

Figure 2-15

- 2) PHILIPS-4W and ISDN digital phones: Just follow the one-to-one relationship as shown in Figure 2-16 below to perform a parallel connection.

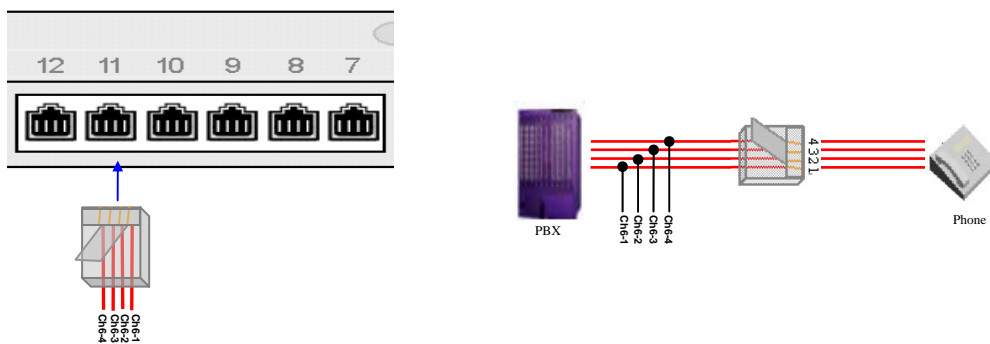

Figure 2-16

- 3) NOTEL M2250 digital phones: See Figure 2-17 below. In parallel, connect the 1st and 2nd leads of the communication line between the PBX and a phone to the 2nd and 3rd pins of each odd-numbered RJ11 jack on the adapter, and the 3rd and 4th leads to the 1st and 4th pins.

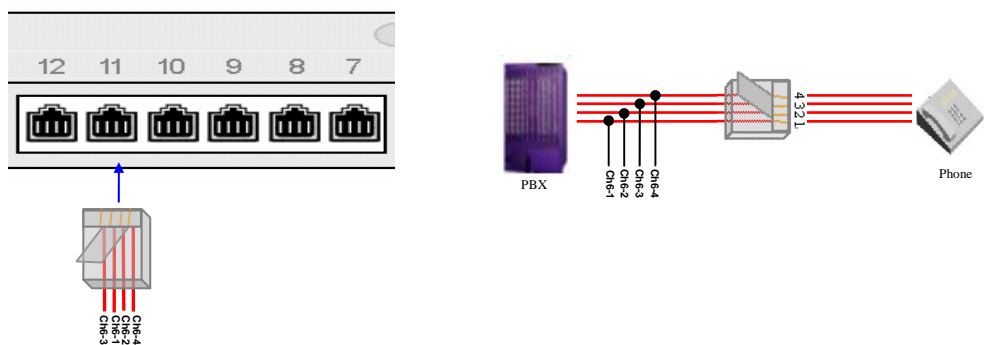

Figure 2-17

- ② In case of direct connection to the on-board RJ21 connector, we suggest the following connection methods:

Method 1:

Connection by 2-lead lines: Simply perform a corresponding connection with CHn-a and CHn-b as shown in Figure 2-18 below.

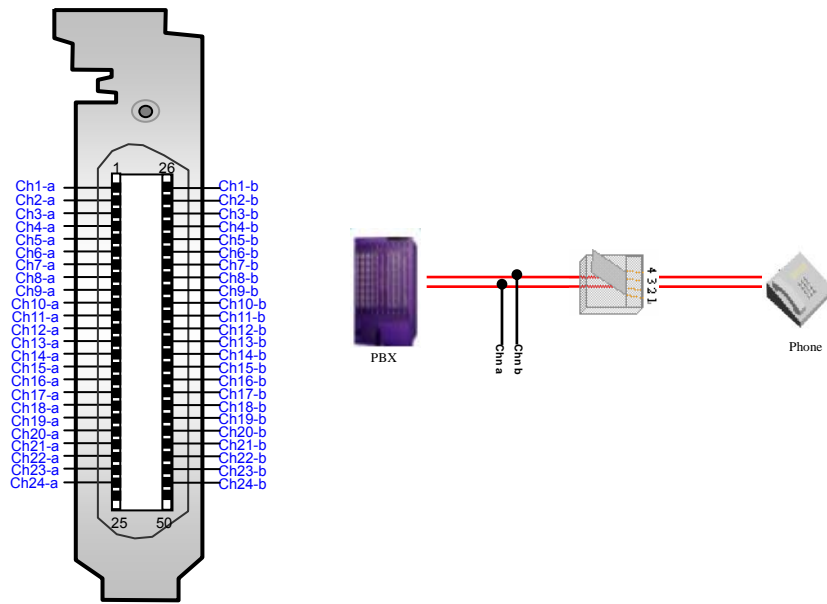

Figure 2-18

Method 2:

Connection by 4-lead lines (e.g. eON, ISDN, AVAYA-4W and PHILIPS-4W): See below for details.

- 1) eON and AVAYA-4W digital phones: See Figure 2-19 below. In parallel, connect the 1st and 2nd leads of the communication line between the PBX and a phone to CHn Tx-a and CHn Tx-b, and the 3rd and 6th leads to CHn Rx-a and CHn Rx-b.
- 2) PHILIPS-4W and ISDN digital phones: See Figure 2-19 below. In parallel, connect the 2nd and 3rd leads of the communication line between the PBX and a phone to CHn Rx-a and CHn Rx-b, and the 1st and 4th leads to CHn Tx-a and CHn Tx-b.

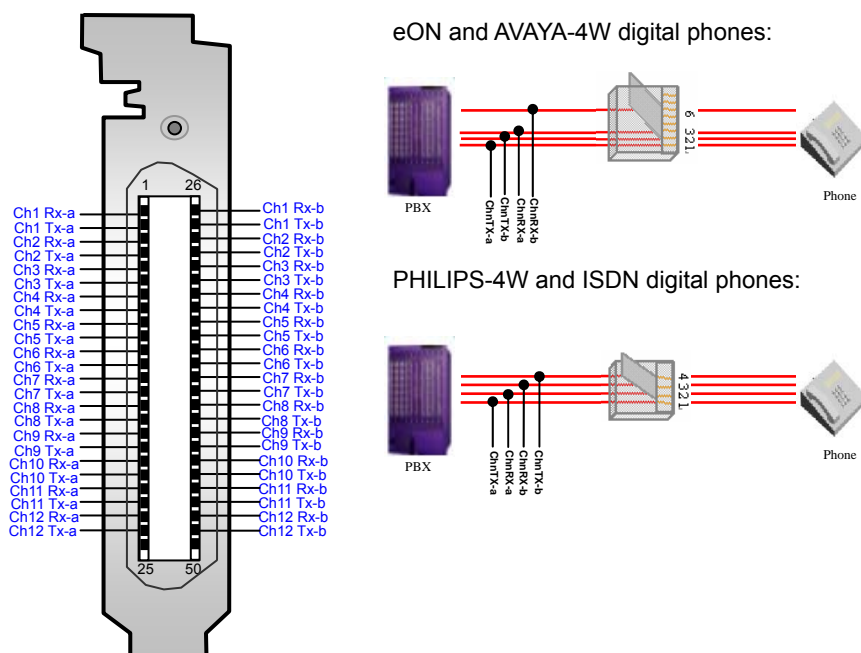

Figure 2-19

- 3) NOTEL M2250 digital phones: See Figure 2-20 below. In parallel, connect the 1st and 2nd leads of the communication line between the PBX and a phone to CHn-1 and CHn-2, and the 3rd and 4th leads to CHn-3 and CHn-4.

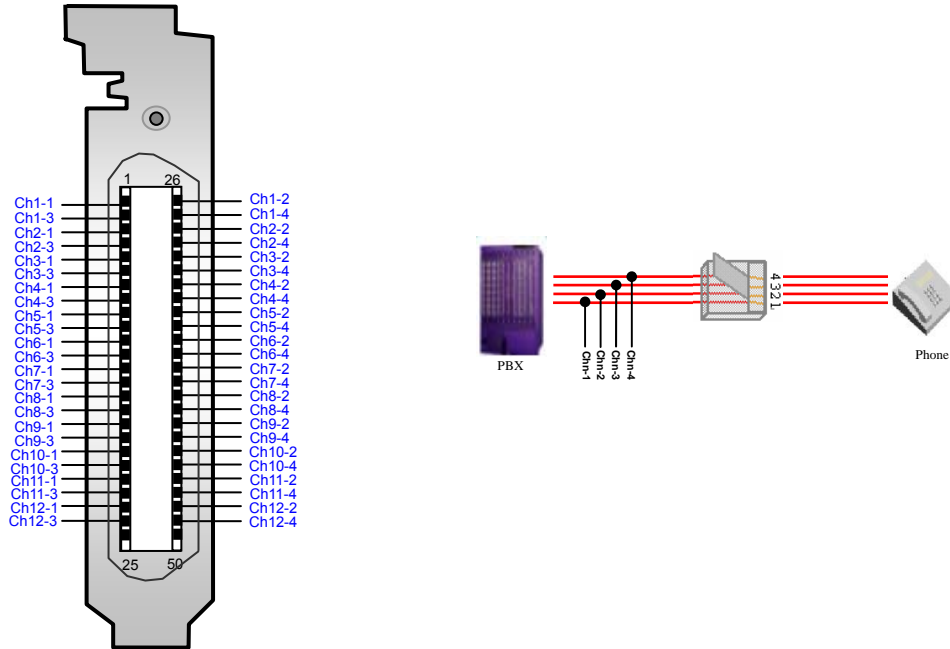

Figure 2-20

Note: The RJ21 connecting line we provide has 3 specifications (3m, 5m and 10m) for you to choose. They are all 25-twisted-pair communication cables using the international standard spectrum, can connect directly to our board. The 25 pairs of pins in RJ21 can be arranged by color in two different ways. See Table 2-1 and Table 2-2 for details. (To be exact, the 1st and the 26th pins are the first pair; the 2nd and the 27th pins constitute the second pair; ...; the 24th and the 49th pins are the 24th pair; the 25th and the 50th pins constitute the 25th pair. Actually, only the first 24 pairs are used by 24-channel boards.)

| | | | | | | | | |
|--------------------|------------------|-----------------|-----------------|-----------------|----------------|------------------|-----------------|-----------------|
| Pair Number | 1 | 2 | 3 | 4 | 5 | 6 | 7 | 8 |
| Color | White Blue | White Orange | White Green | White Brown | White Grey | Red Blue | Red Orange | Red Green |
| Pair Number | 9 | 10 | 11 | 12 | 13 | 14 | 15 | 16 |
| Color | Red Brown | Red Grey | Black Blue | Black Orange | Black Green | Black Brown | Black Grey | Yellow Blue |
| Pair Number | 17 | 18 | 19 | 20 | 21 | 22 | 23 | 24 |
| Color | Yellow Orange | Yellow Green | Yellow Brown | Yellow Grey | Purple Blue | Purple Orange | Purple Green | Purple Brown |

Table 2-1

| | | | | | | | | |
|--------------------|---------------|----------------|-----------------|----------------|---------------|-------------|--------------|---------------|
| Pair Number | 1 | 2 | 3 | 4 | 5 | 6 | 7 | 8 |
| Color | Black Grey | Black Brown | Black Orange | Black Green | Black Blue | Red Grey | Red Brown | Red Orange |

| | | | | | | | | |
|--------------------|--------------|---------------|--------------|--------------|---------------|--------------|--------------|-------------|
| Pair Number | 9 | 10 | 11 | 12 | 13 | 14 | 15 | 16 |
| Color | Red Green | Red Blue | Yellow Grey | Yellow Brown | Yellow Orange | Yellow Green | Yellow Blue | Purple Grey |
| Pair Number | 17 | 18 | 19 | 20 | 21 | 22 | 23 | 24 |
| Color | Purple Brown | Purple Orange | Pruple Green | Purple Blue | White Grey | White Brown | White Orange | White Green |

Table 2-2

- ③ For above parallel connections, the phone lines between the access point and the board should be limited to 15 meters to minimize interruption on monitored lines and to improve monitoring accuracy.

Step 3: Connect the sound box or other proper sound devices.

Skip this step if there is no need to ‘monitor in real time’ or ‘play’.

Regarding how to choose proper sound devices, refer to ‘Input/output Interface’ and ‘Audio Specifications’ in *Appendix A Technical Specifications*.

Step 4: Boot your computer and install the driver.

Regarding driver installation, refer to *SynCti_InstManual.pdf*.

Key Tips:

- As the system is expected to run for long hours unmanned, ‘energy-saving’ mode should be turned off for both the CPU and the HD in CMOS or WINDOWS operating system. This is to ensure full-speed operation of the computer, or it may lead to a drop in performance or unexpected errors after running for some time.
- A chassis installed with digital station tap boards must be grounded for safety reasons, according to standard industry requirements. A simple way is earthing with the third pin on the plug. No or improper grounding may cause instability in operation as well as decrease in lightning resistance.

Appendix A Technical Specifications

Dimensions

DST-24B/PCI, DST-24B/PCI+:
 310×115mm² (excluding L-bracket)
 DST-24B/PCI(2.0), DST-24B/PCI+(2.0),
 DST-24B/PCle(2.0), DST-24B/PCle+(2.0):
 160×111mm² (excluding L-bracket)

Weight

DST-24B/PCI, DST-24B/PCI+:
 ≈ 250g (including 2 8-port recording modules)
 DST-24B/PCI(2.0), DST-24B/PCI+(2.0),
 DST-24B/PCle(2.0), DST-24B/PCle+(2.0):
 ≈ 200g (including 2 8-port recording modules)

Environment

Operating temperature: 0 °C—55 °C
 Storage temperature: -20 °C—85 °C
 Humidity: 8%—90% non-condensing
 Storage humidity: 8%—90% non-condensing

Input/output Interface

Headset jack: One ϕ 3.5 stereo jack
 Telephone line jack: One 50-pin RJ21 connector

Audio Specifications

Codec: CCITT A/ μ -Law 64kbps
 IMA ADPCM 32kbps
 High compression recording format:
 GSM 13.6kbps
 G.729A 8kbps
 MP3 8kbps, 16kbps
 Output power: \geq 50mW
 Distortion: \leq 2%
 Frequency response: 300-3400Hz(\pm 3dB)
 Signal-to-noise ratio: \geq 38dB

Maximum System Capacity

Up to 10 boards concurrently per system; up to
 24 channels per board

Power Requirements

DST-24B/PCI, DST-24B/PCI+:
 +3.3V DC: 1500mA
 +5V DC: 200mA
 -12V DC: 20mA
 +12V DC: 100mA
 Maximum power consumption: \leq 12W
 (PC power supply only)
 DST-24B/PCle(2.0), DST-24B/PCle+(2.0):
 +3.3V DC: 1300mA
 +12V DC: 350mA
 Maximum power consumption: \leq 8.5W
 (PC power supply only)
 DST-24B/PCI(2.0), DST-24B/PCI+(2.0):
 +3.3V DC: 1300mA
 +5V DC: 50mA
 +12V DC: 300mA
 Maximum power consumption: \leq 8.5W
 (PC power supply only)

Impedance

Input impedance: \geq 1000 Ω AC
 Insulation resistance for PC isolation from
 telephone line: \geq 20M Ω /500V DC

Audio Encoding & Decoding

| | |
|------------|---------------|
| 16Bit PCM | 128kbps |
| 8Bit PCM | 64kbps |
| A-Law | 64kbps |
| μ -Law | 64kbps |
| VOX | 32kbps |
| ADPCM | 32kbps |
| GSM | 13.6kbps |
| MP3 | 8kbps, 16kbps |
| G.729A | 8kbps |

Sampling Rate

8kHz

Safety

Lightning resistance: Level 4

Appendix B Technical/sales Support

Thank you for choosing Synway. Please contact us should you have any inquiry regarding our products. We shall do our best to help you.

Headquarters

Synway Information Engineering Co., Ltd

<http://www.synway.net/>

9F, Synway D&R Center, No.3756, Nanhuan Road, Binjiang District, Hangzhou, P.R.China, 310053

Tel: +86-571-88860561

Fax: +86-571-88850923

Technical Support

Tel: +86-571-88864579

Mobile: +86-13735549651

Email: techsupport@sanhuid.com

Email: techsupport@synway.net

MSN: scycindy_sh@hotmail.com

Sales Department

Tel: +86-571-88860561

Tel: +86-571-88864579

Fax: +86-571-88850923

Email: sales@synway.net